

**8th International Workshop on Internet Charging and QoS
Technologies
ICQT'13
Zurich October 14th 2013**

**E-Africa by the horizon 2020
Ultra Wide Band in Africa ? A mainly political choice**

C de Jacquelot
ICT political advisor
Jacquelot@aol.com

summary

1. An economical transformation for governments which have to move to ICT, cash cow of the state budget driven by an E-economy.
2. Wide band? What for? How do consumers use it?
3. How to serve wide band on the short and middle term (2016) and ultra wide band by the horizon 2018-2020.
4. Impacts on infrastructures and the regional integration problem.

All the different points are illustrated by lessons based on the Programm for Infrastructure Development in Africa (PIDA) and country case studies.

CJBMI & ass

Voice and Internet... every where in the world ?

Growth in Mobile Connections

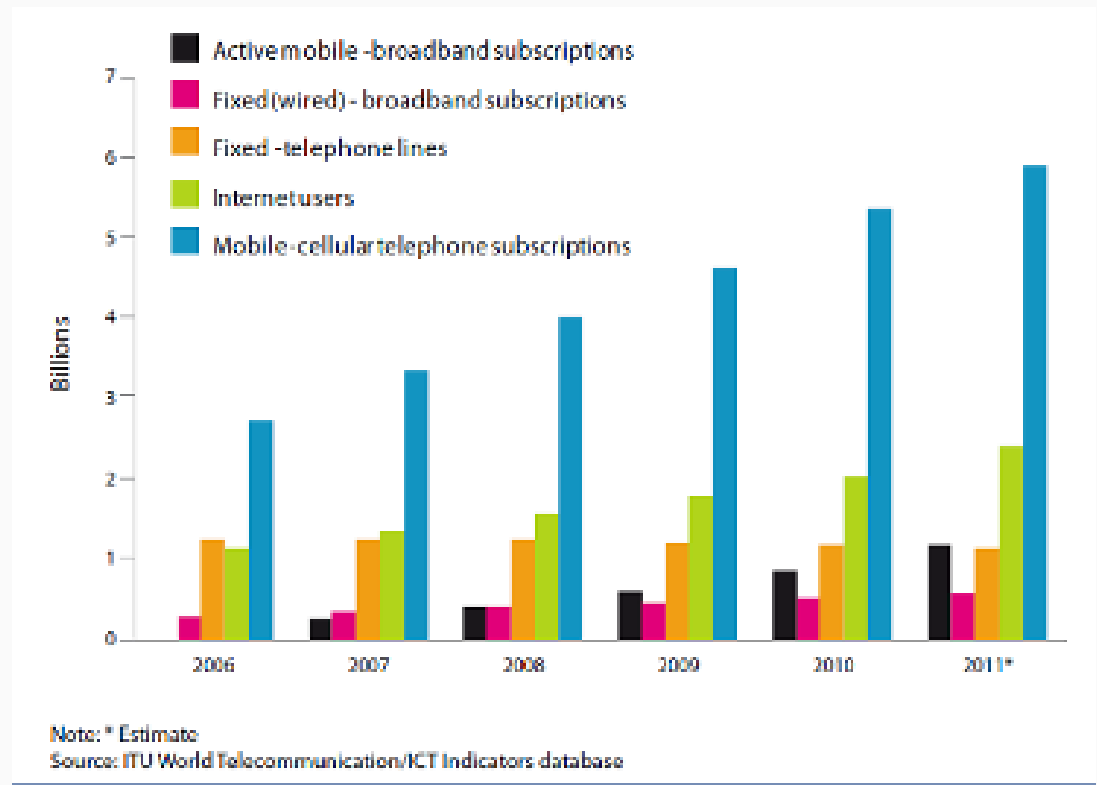
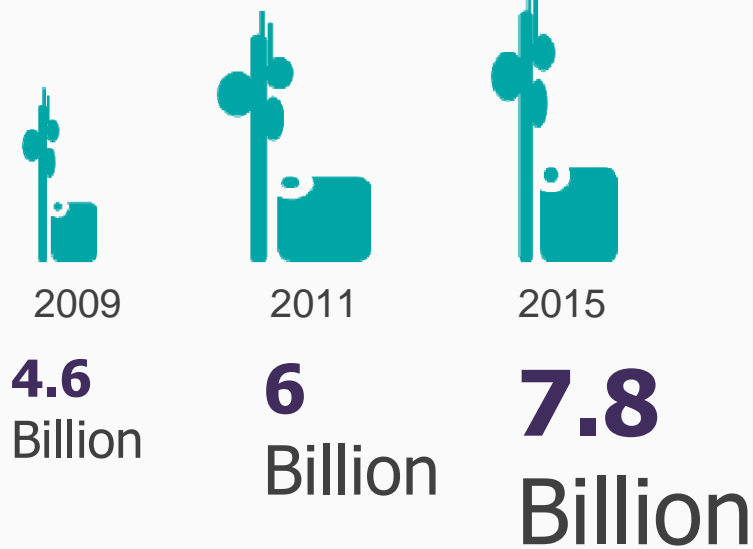

Mobile-cellular subscriptions per 100 inhabitants, world

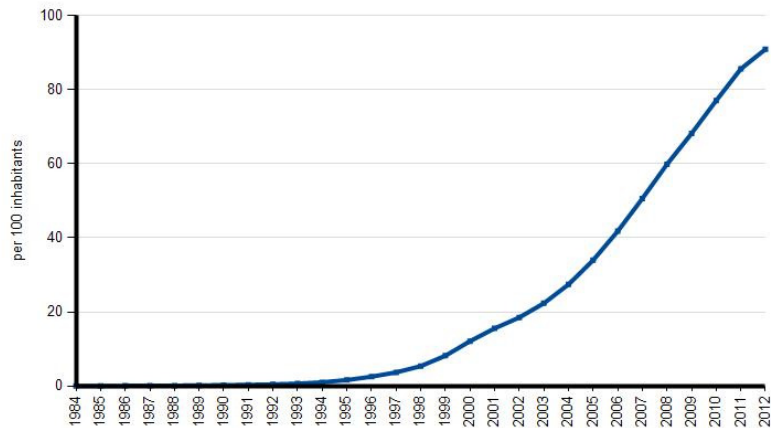

Based on 226 data points for 2012

ITU ICT-Eye: <http://www.itu.int/ict/eye>



High speed Internet : the XXIth century challenge

3 main axis with horizons 2015-2030

NATIONAL AND REGIONAL DIGITAL PROGRAMMES

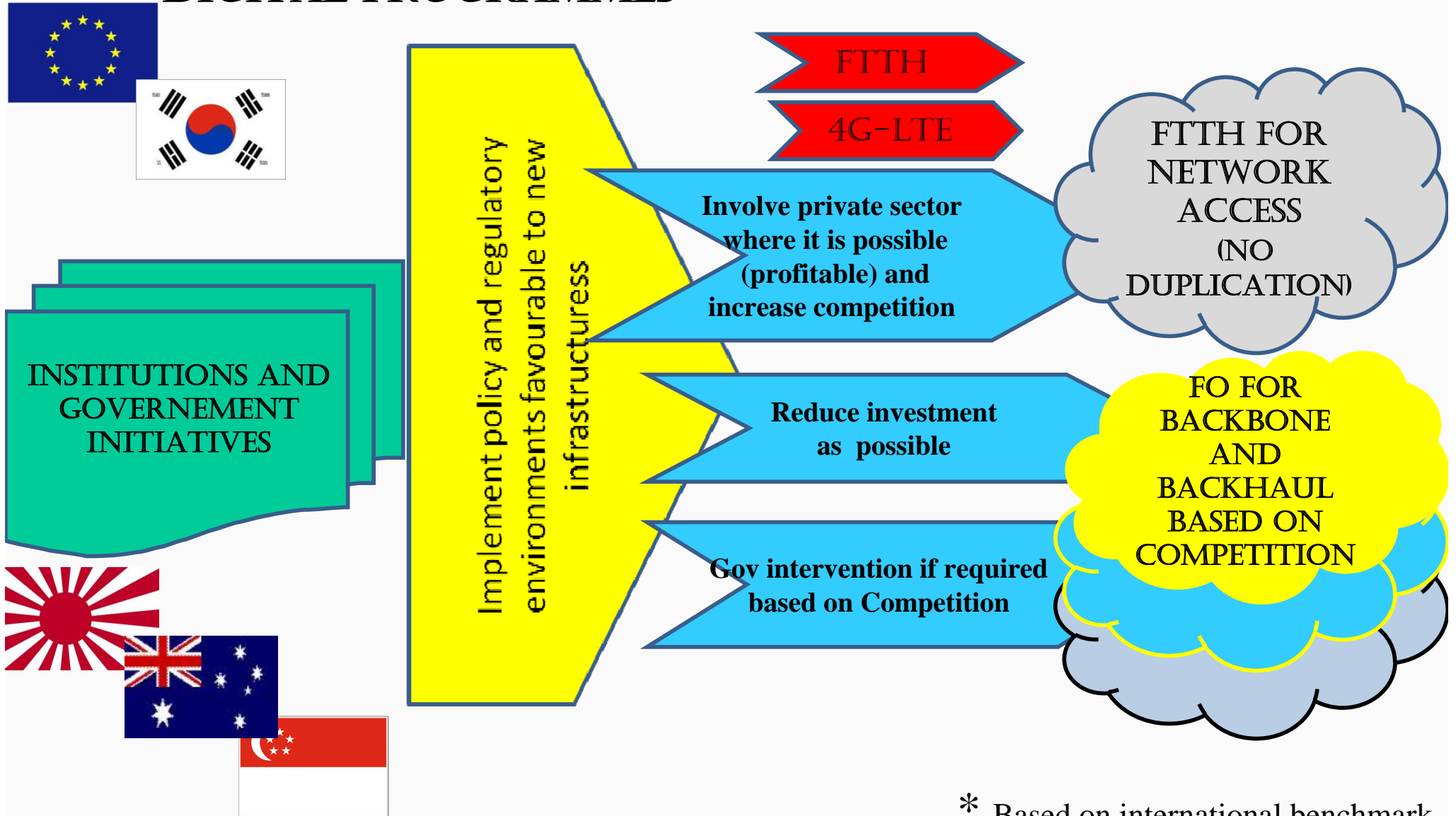

* Based on international benchmark

NGA networks- A challenge for developed countries

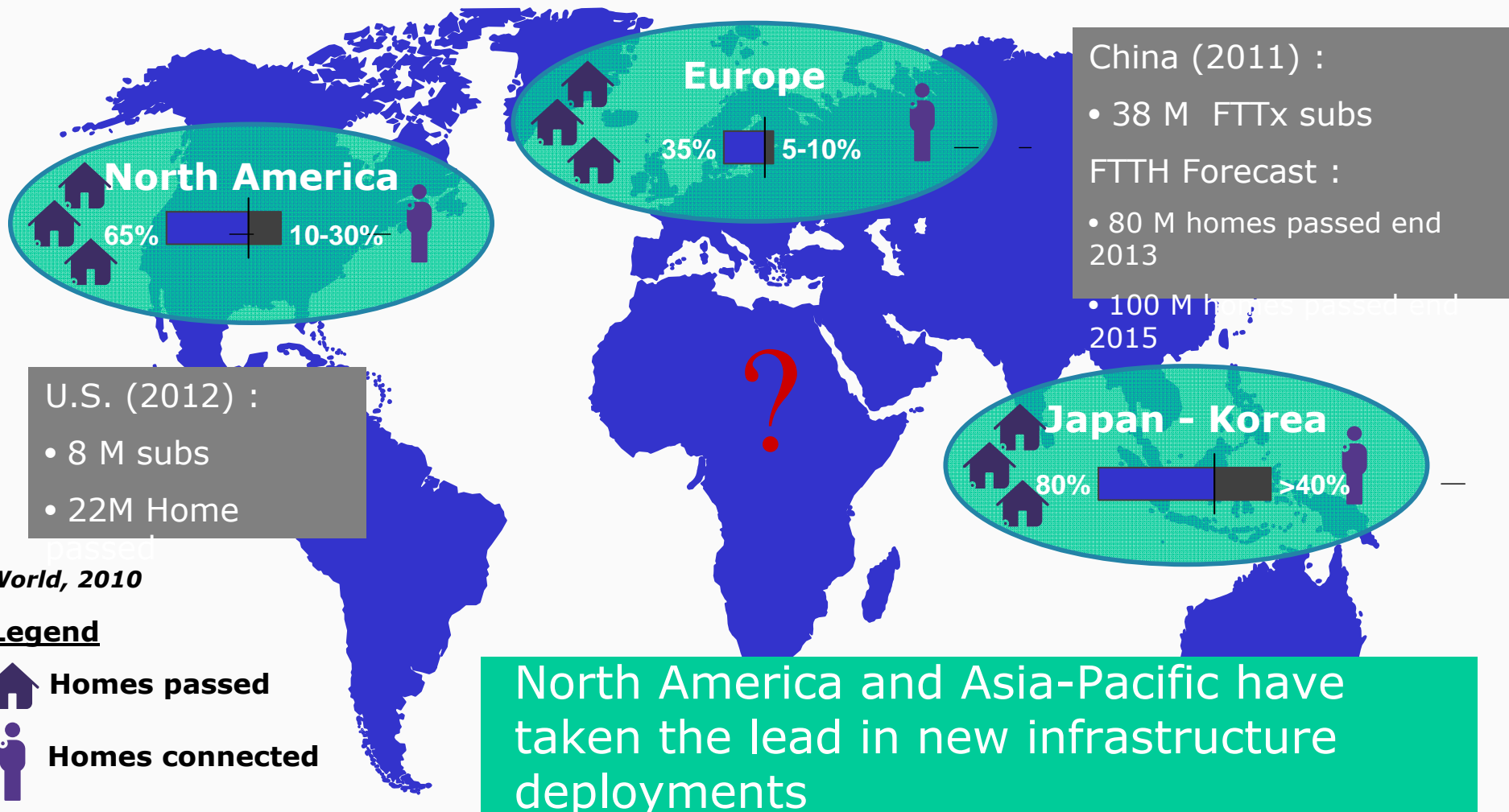

Source: Arthur D. Little, Exane BNP Paribas, Analysys Mason, IDATE

NGA includes wireline technologies providing ultra fast broadband (all FTTx technologies and DOCSIS 3.0)

Potential new Digital divide Africa vs rest of the world

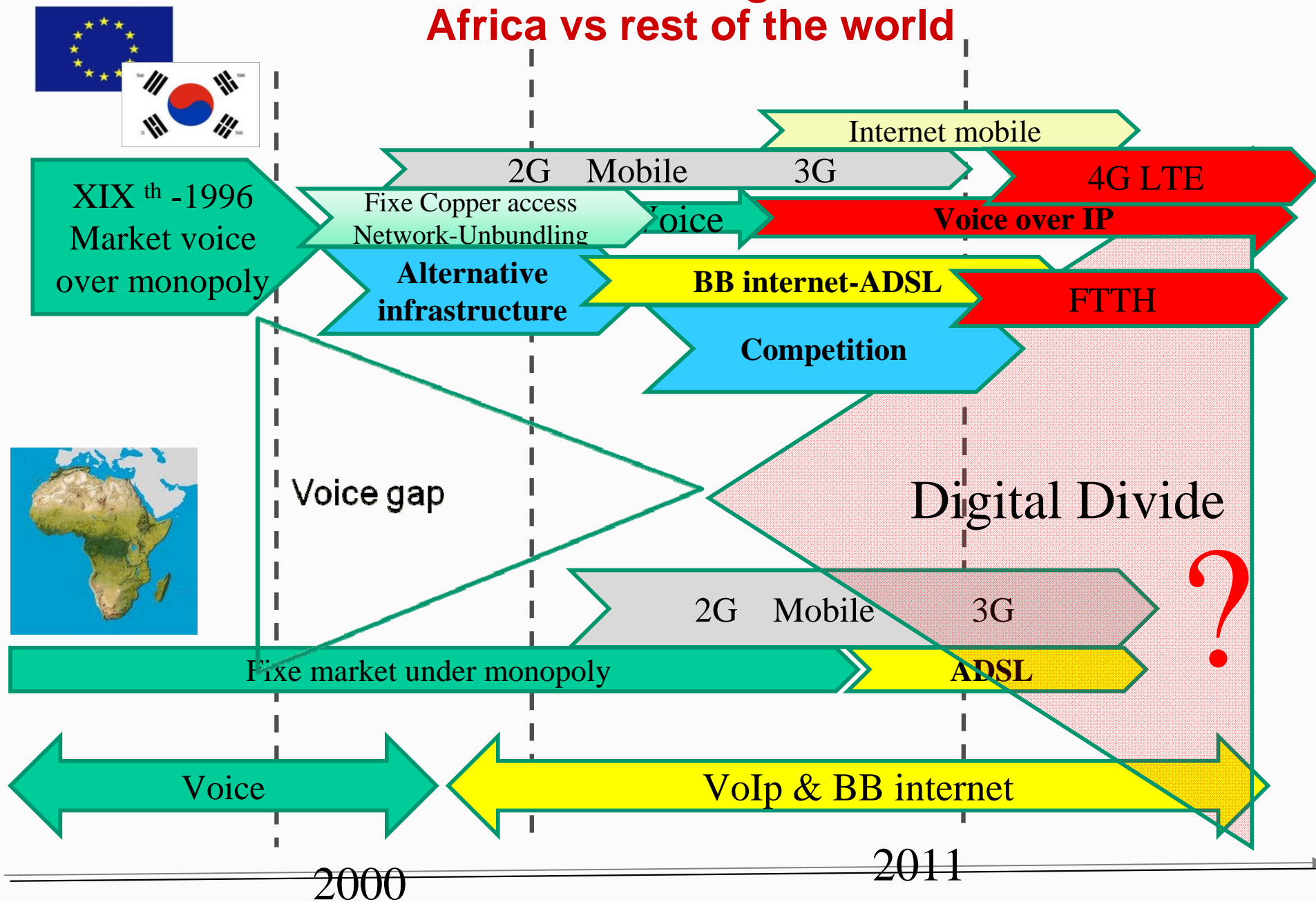

e world
concept

The new african challenge

e Africa 2020

8

The Vision: e-Africa 2020 a Digital Africa

An Africa based on Information society and e-economy

➤ Develop

- E-Government
- E-Commerce
- Social Networks & Email
- Telephony and video calls
- IPTV

➤ To support:

- Economic development - GDP growth, jobs
- Social inclusion - elimination of isolation
- Regional Integration - trade, decision-making
- Equal participation on the global stage
- Improved peace & security
- Meeting the Millennium Development Goals



The Context Impact on BB development on Traffic in developing countries

1. Exploding growth in bandwidth requirements to respond to the demand from customers at:

- ✓ Local Level
- ✓ National level
- ✓ Regional level
- ✓ International level

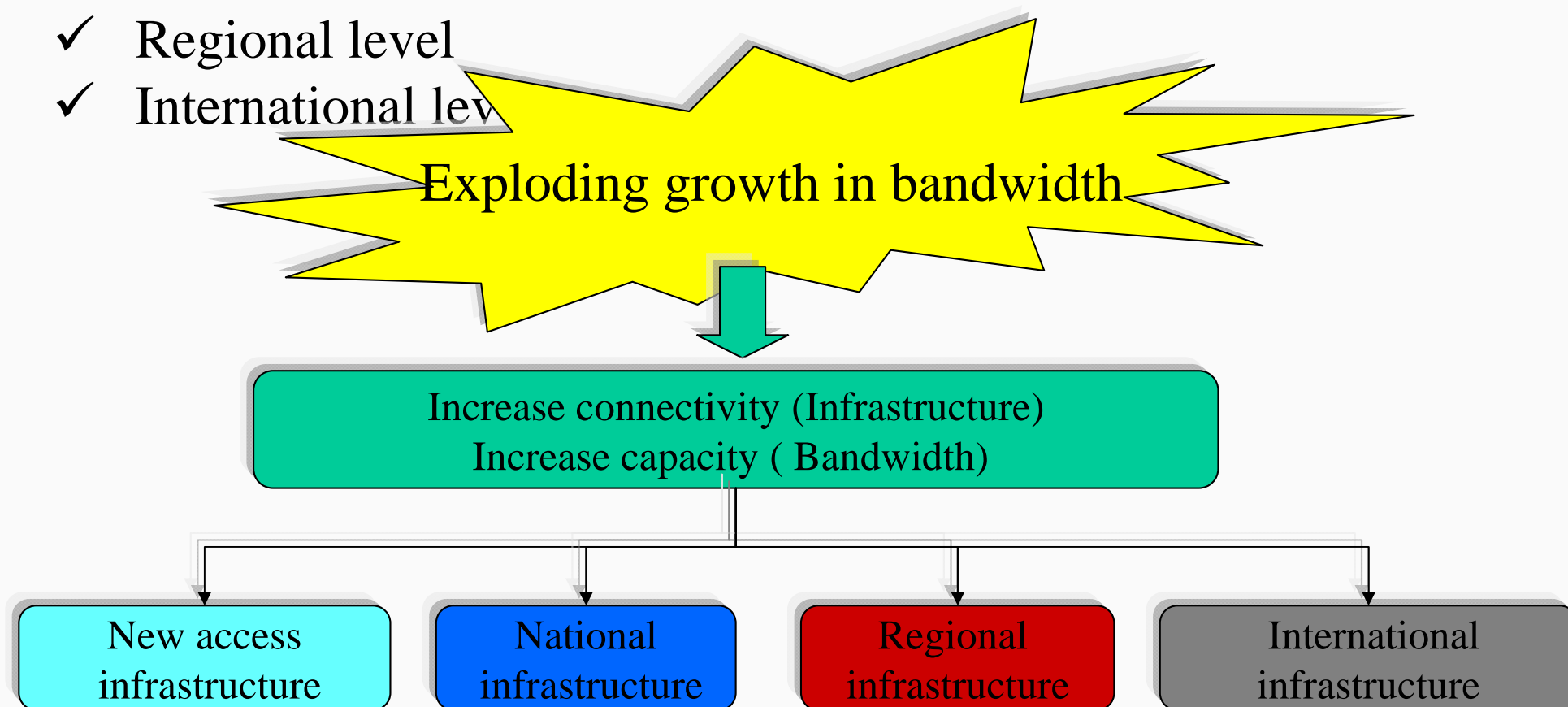

Fixed Access infrastructure divide

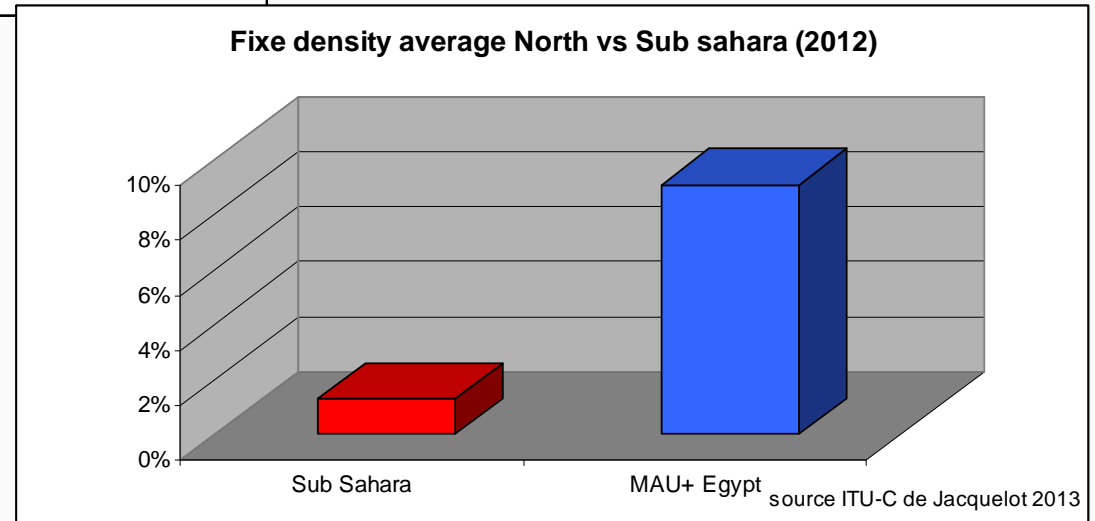
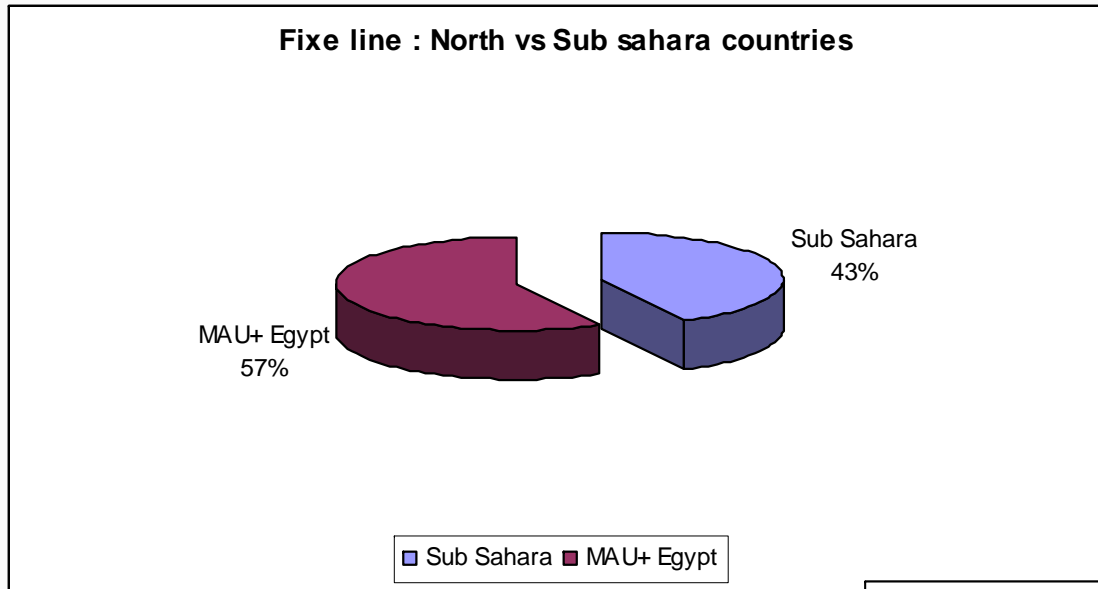

A context which impact the Broadband development model between developed and developing countries

Infrastructure and Voice market release Mobile before 2011

- ▶ 2 major issues on voice service prices:
 - ▶ Interconnection –Call terminaison
 - ▶ Taxe on international call

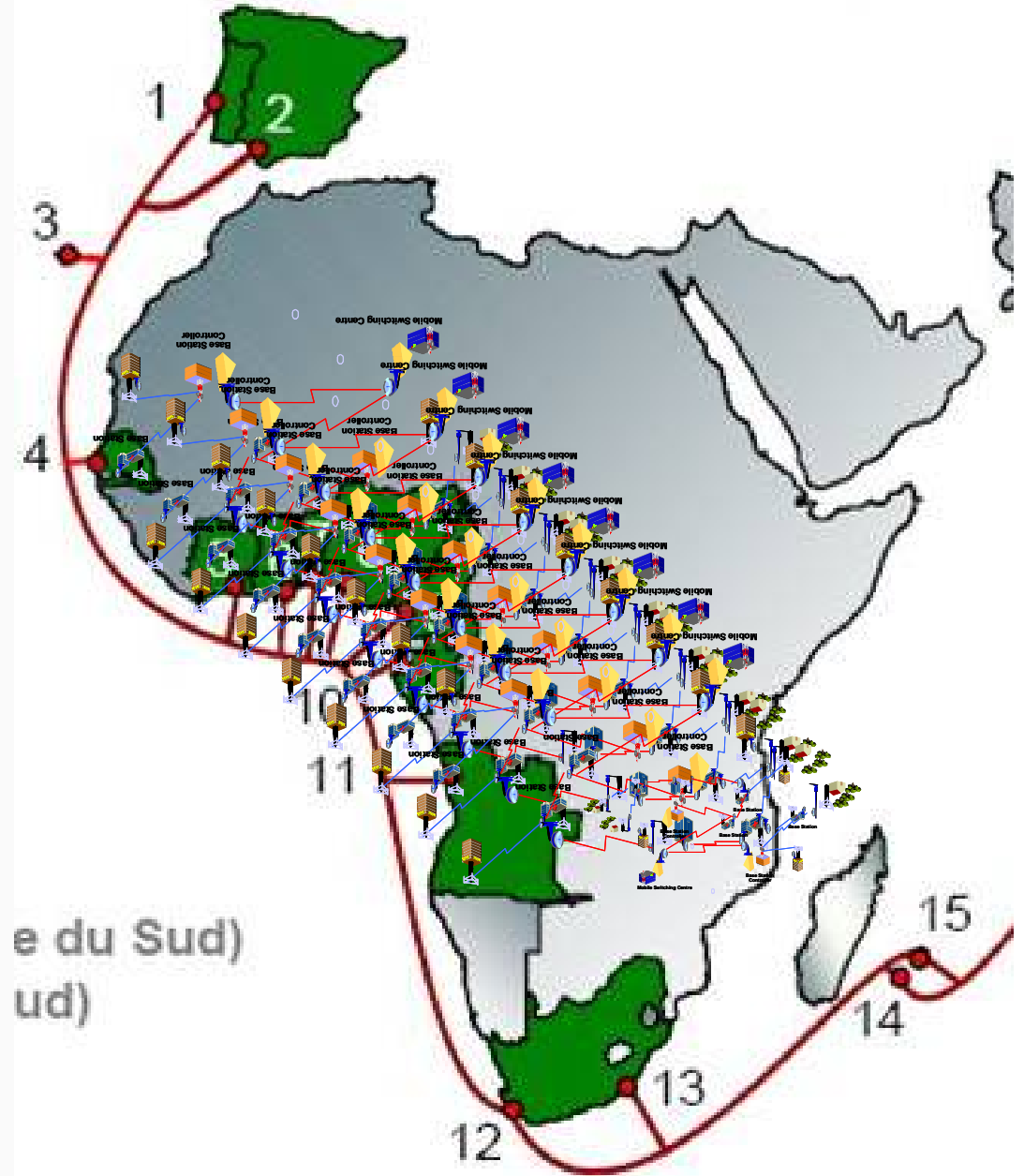

Mobile market in Africa

2G vs 3G Countries in Africa

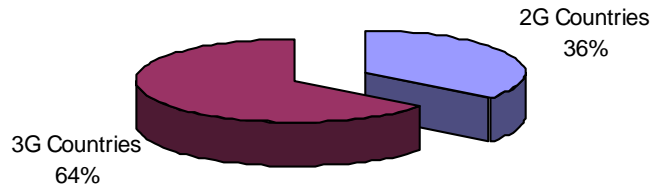

Mobile market in Africa competition status

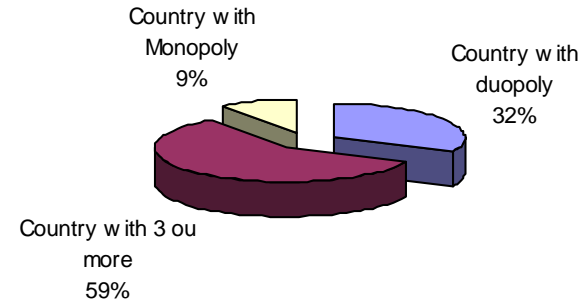

3G data services : status of competition

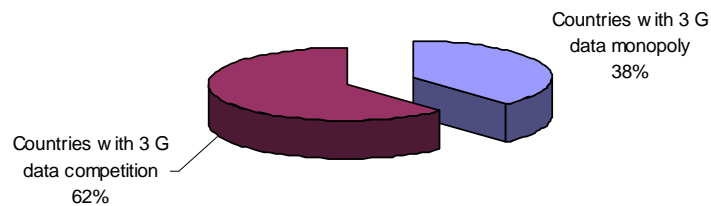

A market in progress

Africa 2G-3G



- 3G data active with competition
- 3G data active no competition
- 3G data active with monopoly
- 2G data active with competition
- 2G active with monopoly

Internet Users in Africa

**Internet Users in Africa
2012 - Q2**

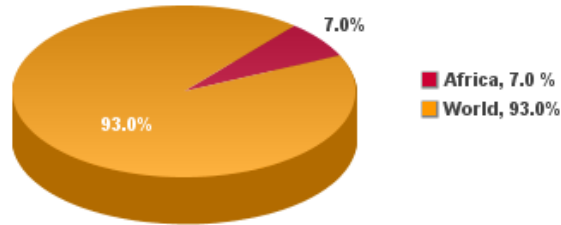

Source: Internet World Stats - www.internetworldstats.com
167,335,676 estimated Internet users in Africa for 2012Q2
Copyright © 2012, Miniwatts Marketing Group

**Internet Penetration in Africa
2012 Q2**

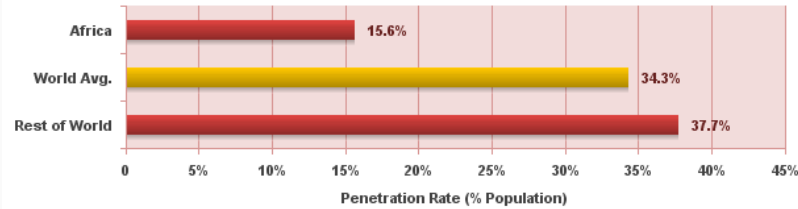

Source: Internet World Stats - www.internetworldstats.com/stats1.htm
167,335,676 estimated Internet users in Africa for June 30, 2012
Copyright © 2012, Miniwatts Marketing Group

**Africa Top 10 Internet Countries
2012 Q2**

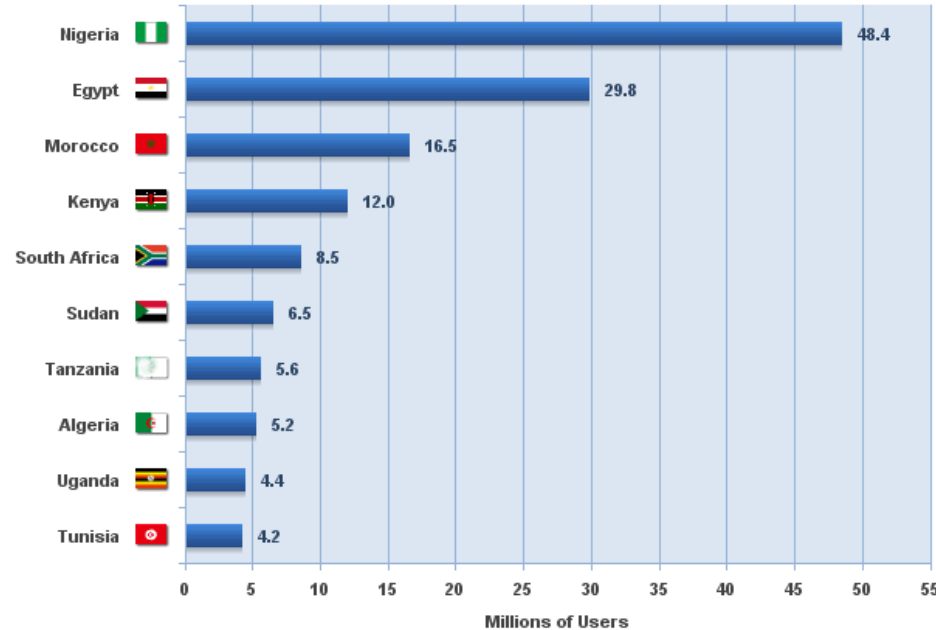

Source: Internet World Stats - www.internetworldstats.com/stats1.htm
167,335,676 Internet Users in Africa estimated for June 30, 2012
Copyright © 2012, Miniwatts Marketing Group

Political aspects of ICT development in Africa

ICT will become an engine to e economy

Has been ICT



ICT in a new world

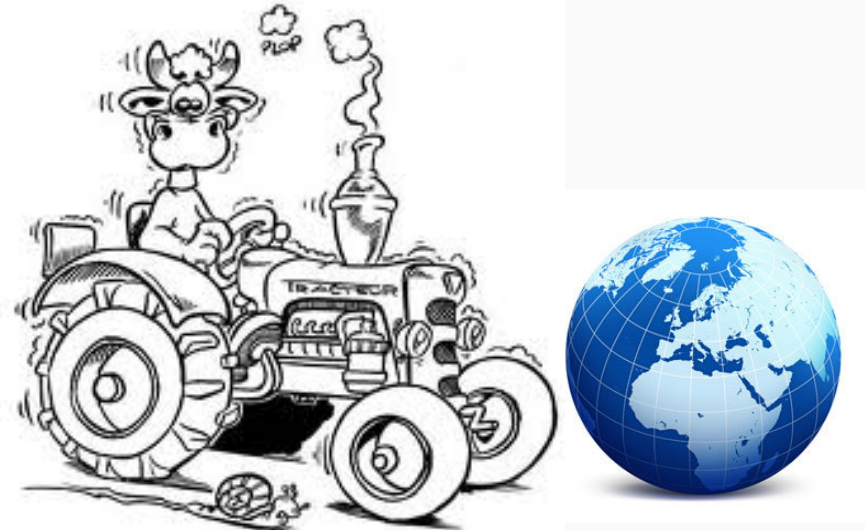

How to success this challenge ?

International access

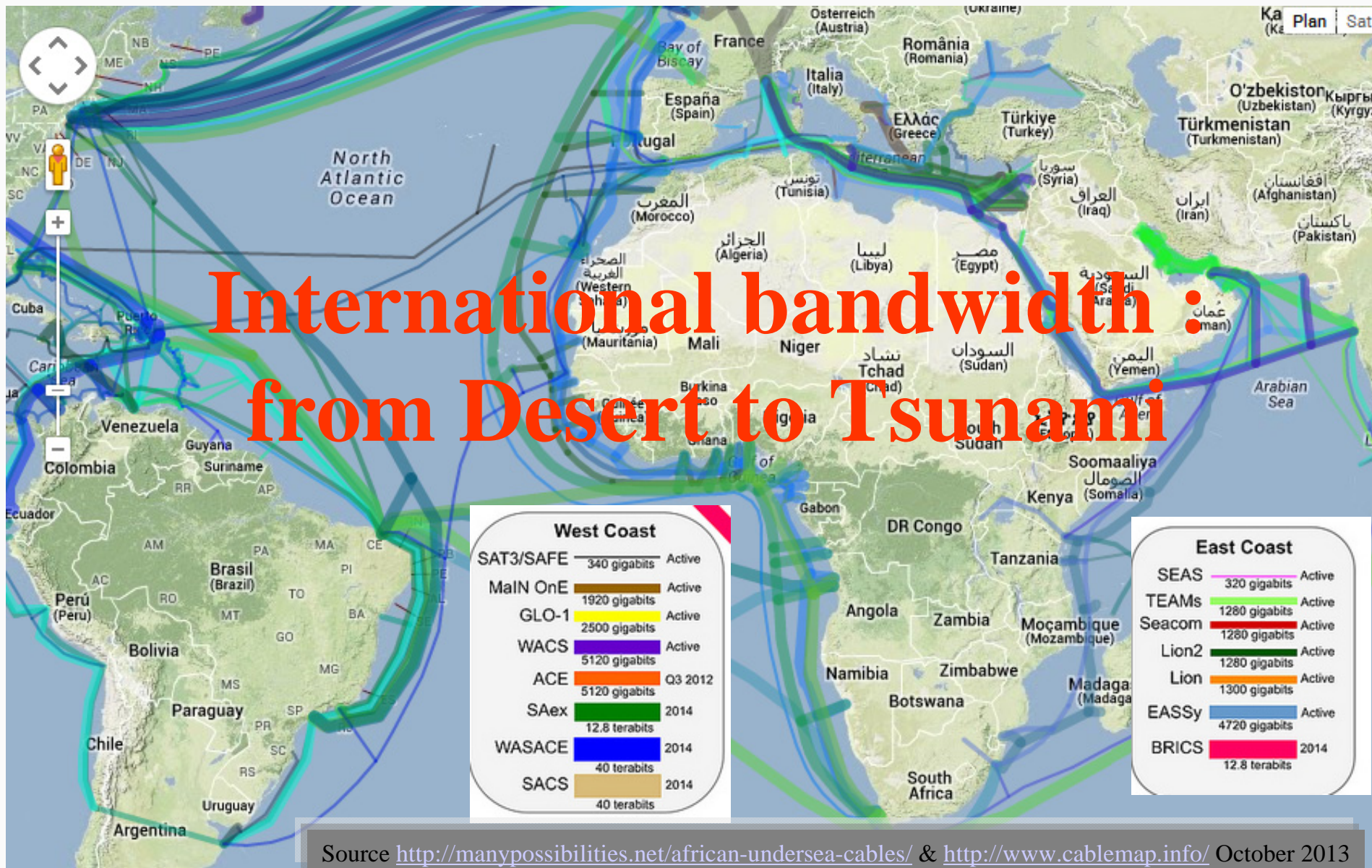

International traffics : Africa and Voice VS IP (Libya case)

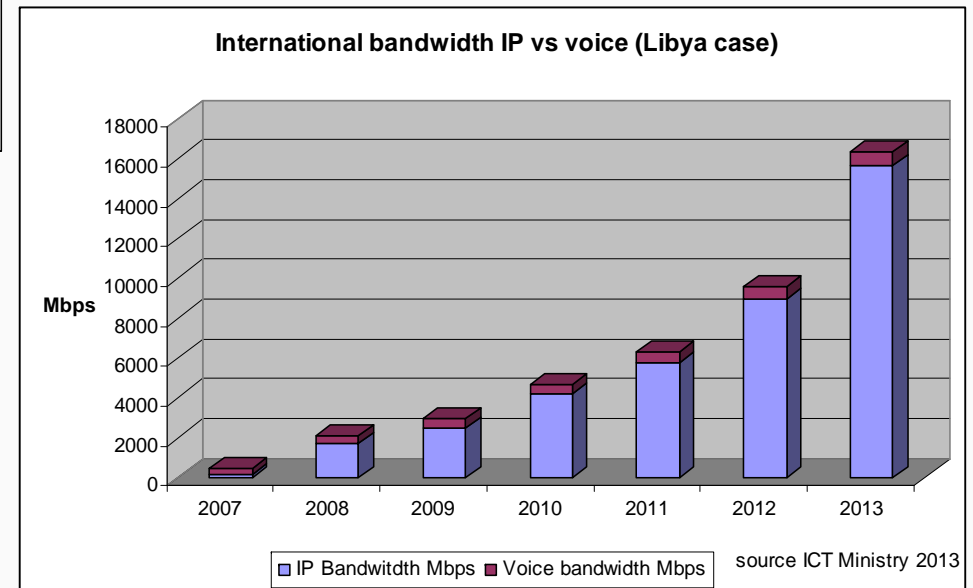
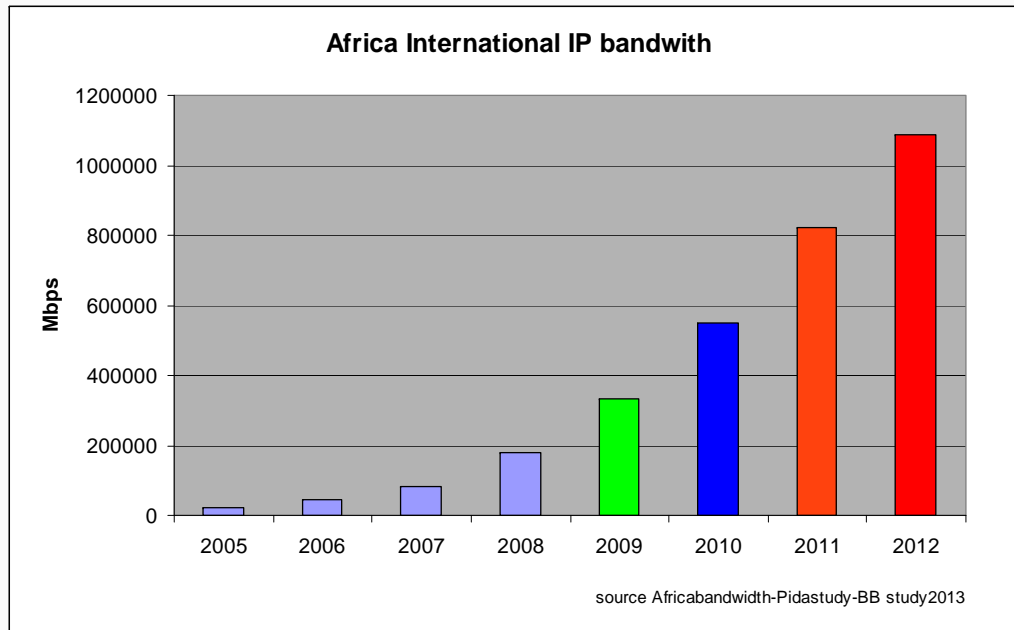

Ip traffic is growing under customers' demand and voice traffic becomes residual

Internet growth's indicator: ASN- World vs Africa

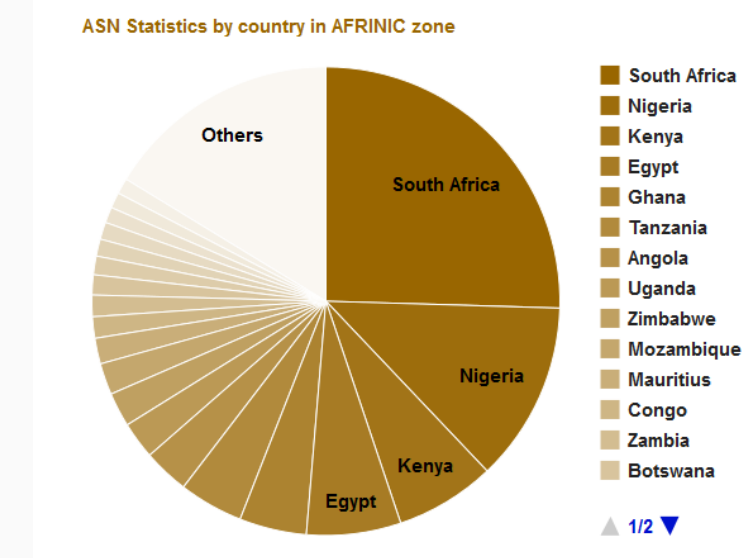
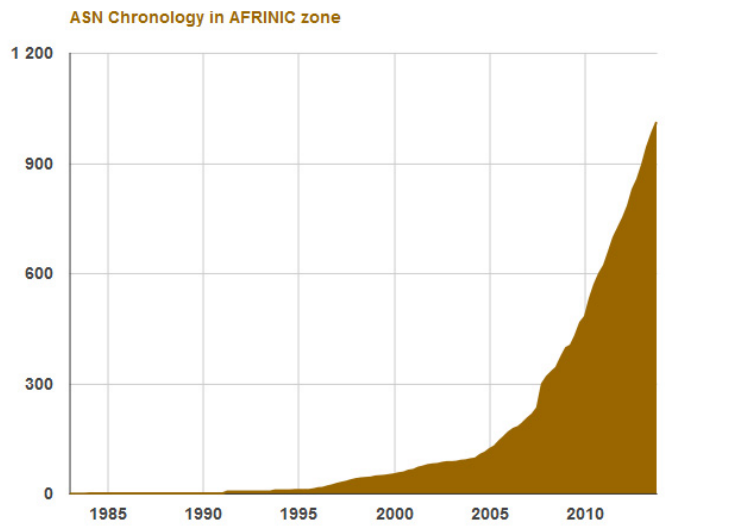
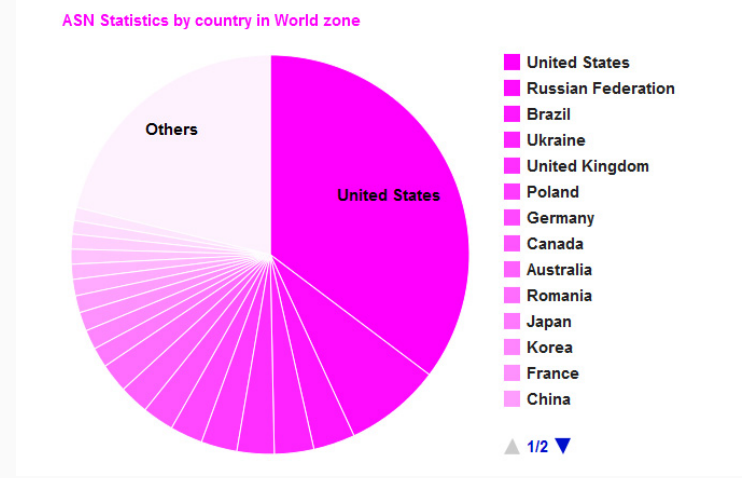
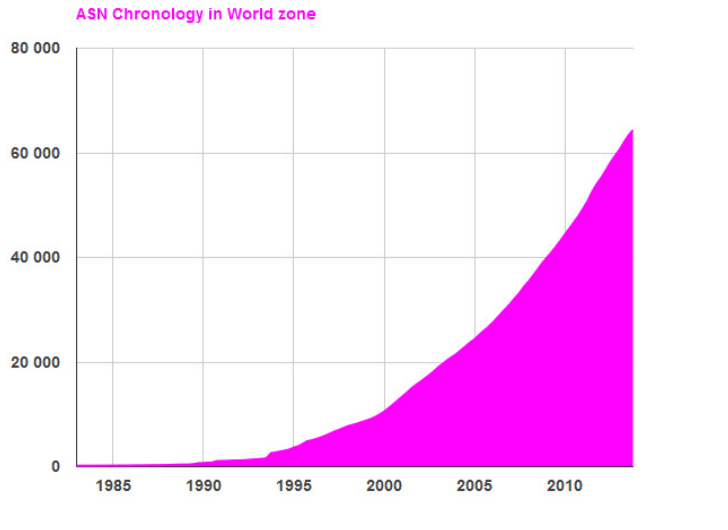

Source Data from RIR websites as of: Sun Oct 06 2013

A growth more important than is the rest of the world but still gap exists

Who is the African consumer ? How is he connected ?

E government

Economic development

World integration

Accès au Savoir

?

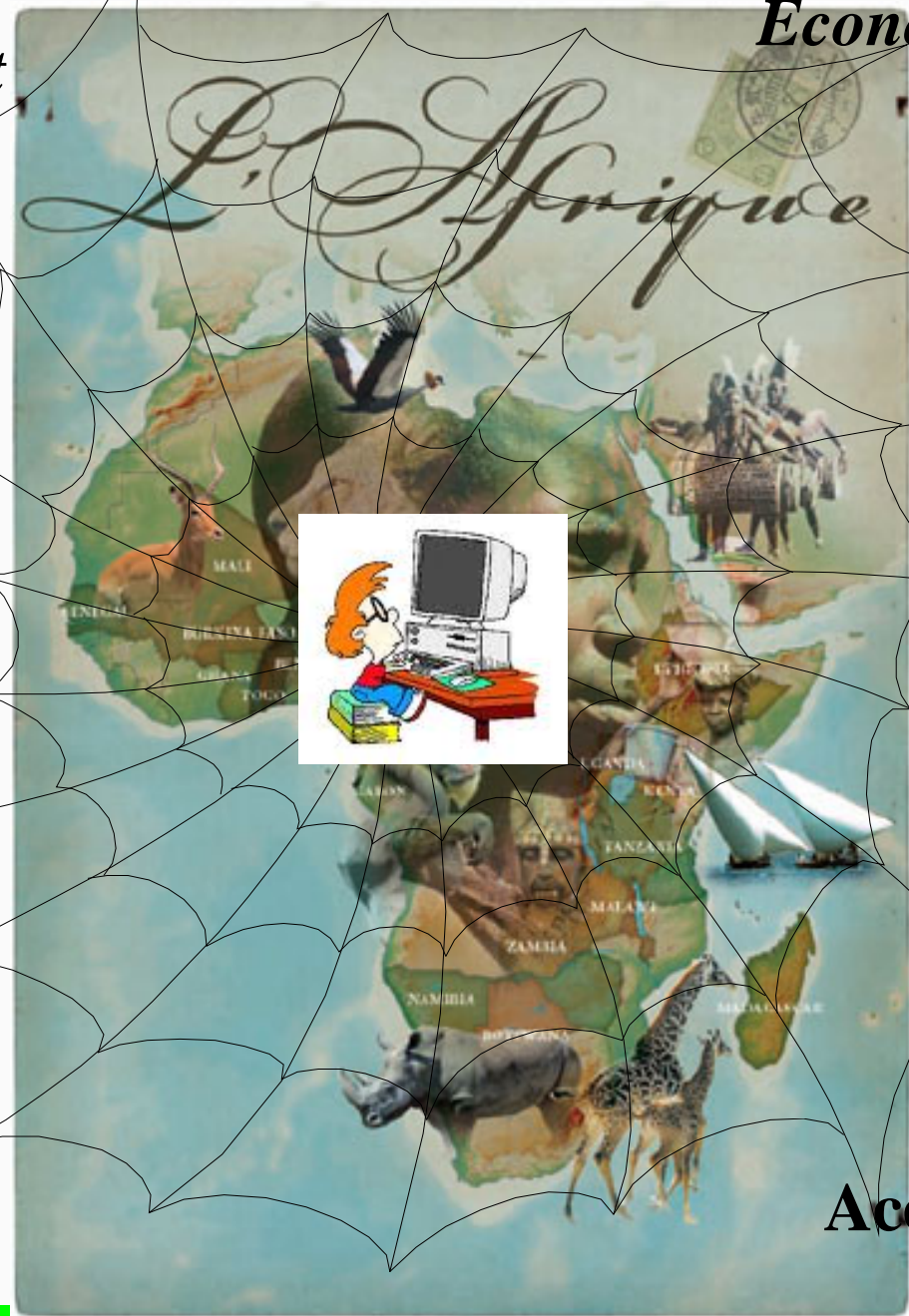

A draft of response loaded of lessons...

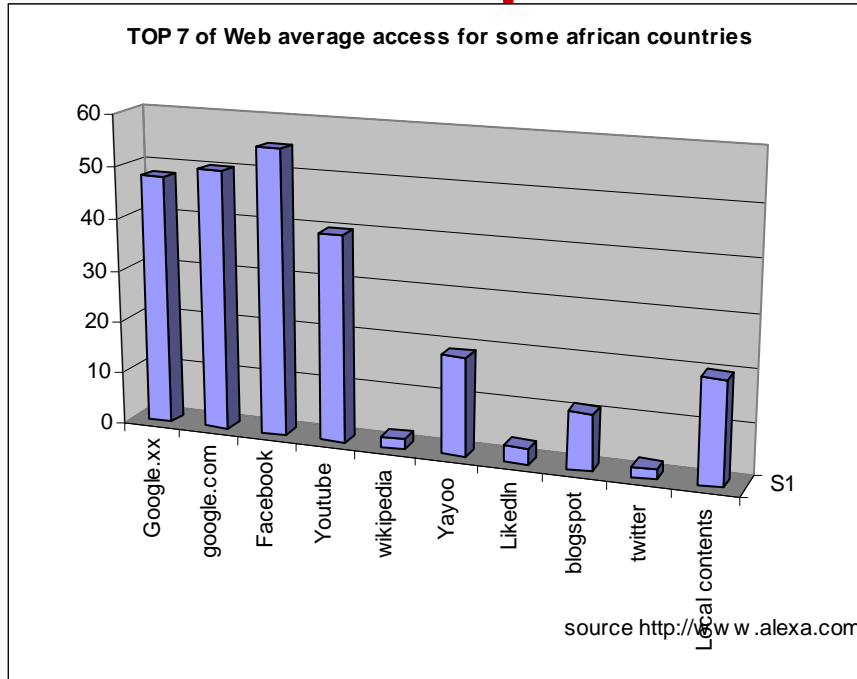

Africa consumer = European consumer

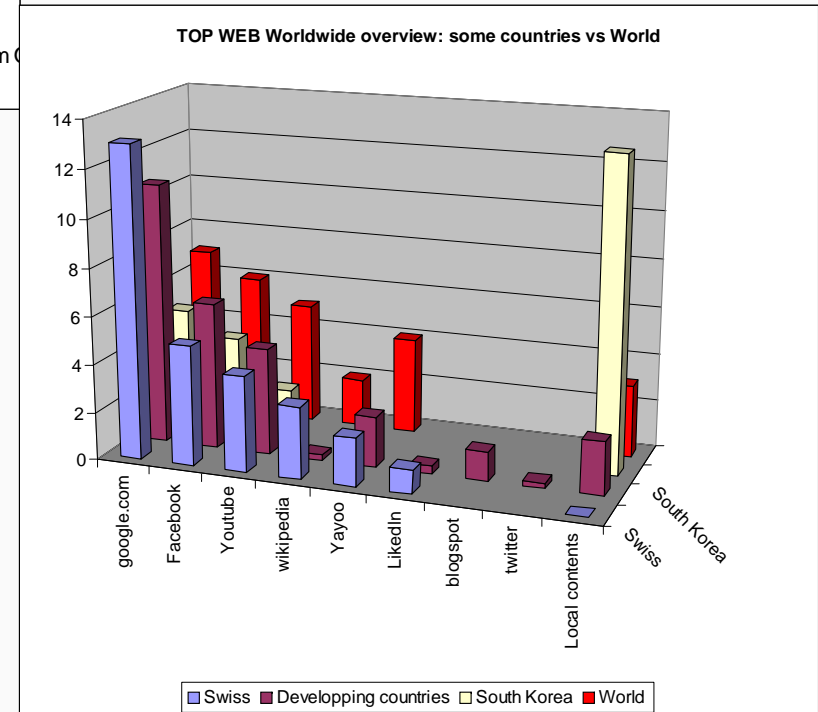

What are the generated traffics ? European case

Migration from B & R traffics to pure residential traffic

Week End Residential traffic

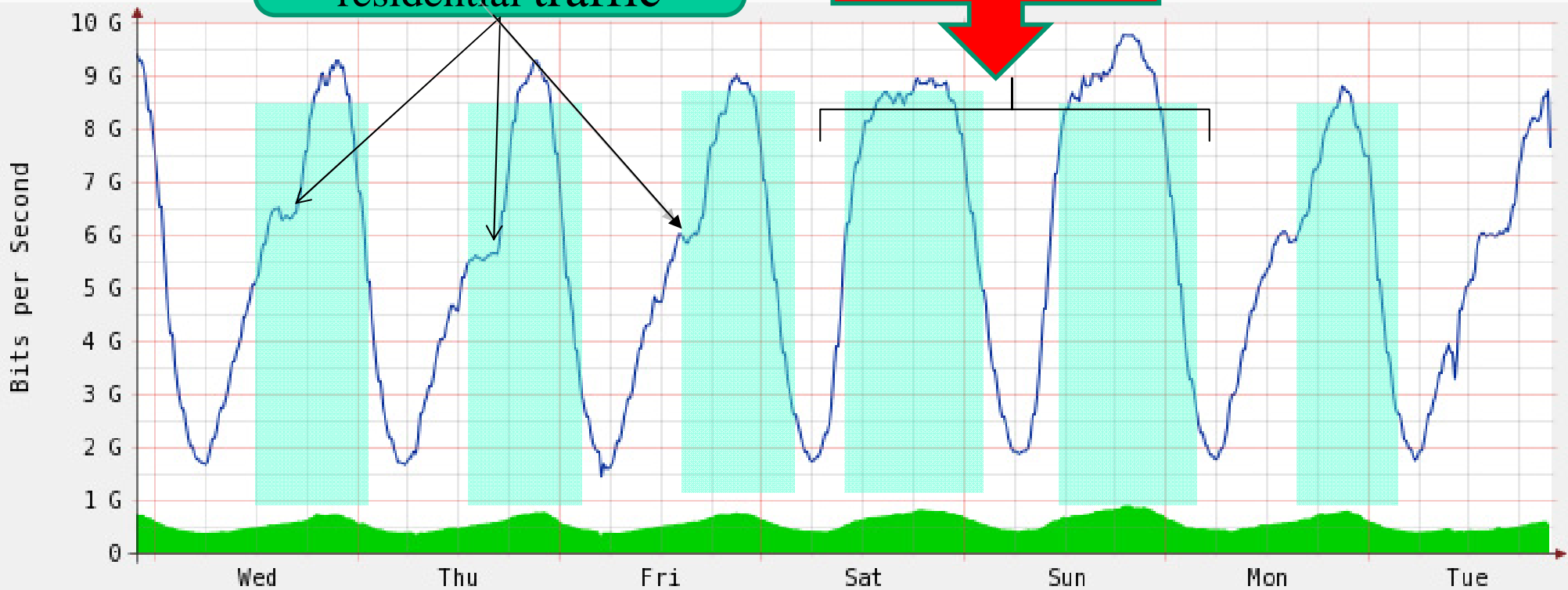

Graph from 18.Jan 2011 20:45 till 25.Jan 2011 20:45 (UTC)

■ Inbound	Last	514.54 Mbit/s	Average	554.21 Mbit/s	Maximum	886.88 Mbit/s
■ Out		7.66 Gbit/s	Average	5.70 Gbit/s	Maximum	9.78 Gbit/s

Residential traffic



In Europe Residential BB traffic is the heavy one

What are the generated traffics ? South Africa case

Last 24 hours

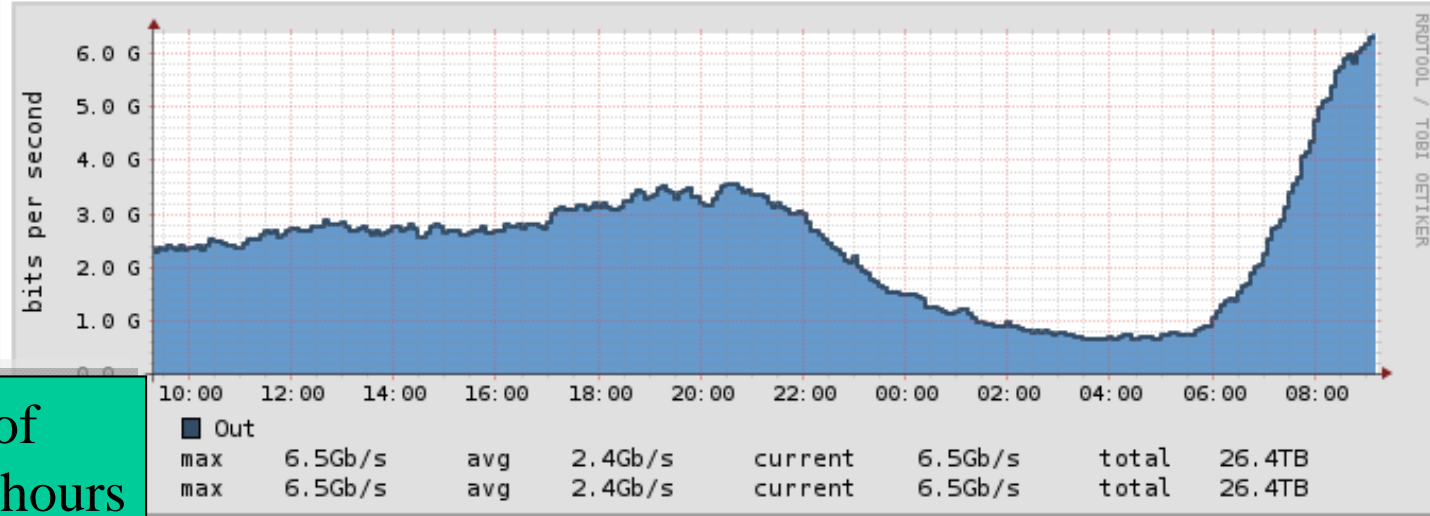

End of working hours

Last 7 days

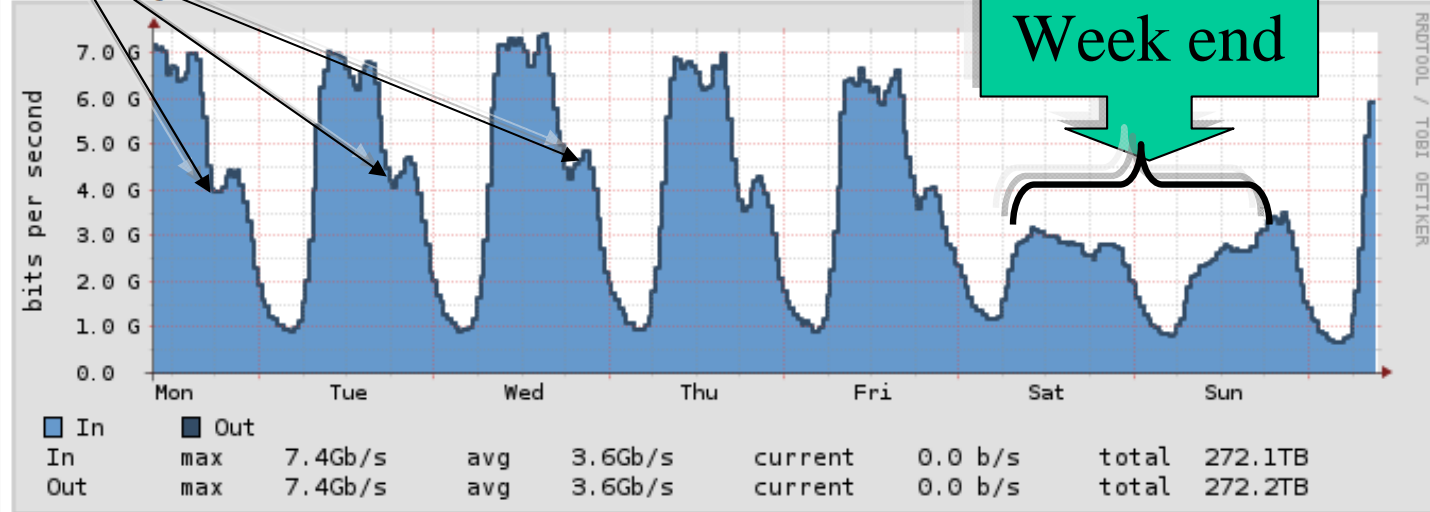

Week end

What are the generated traffics ? Nigeria per Submarine cable access

'Monthly' Graph (2 Hour Average)

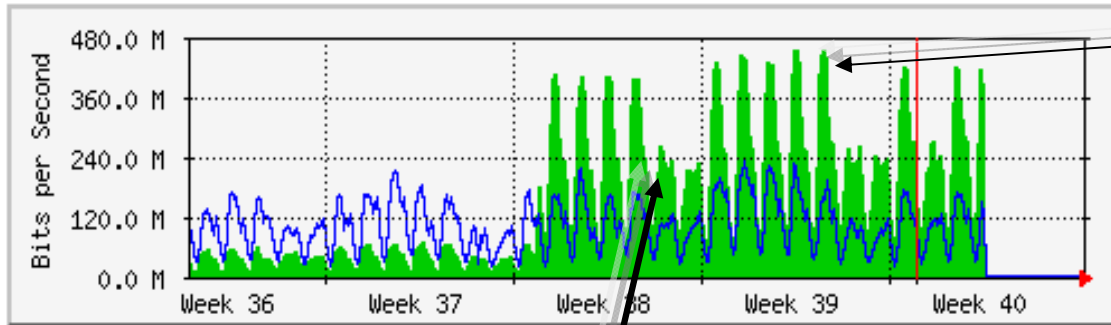

Max Average Current

End of working hours

Mainone

Week end

'Monthly' Graph (2 Hour Average)

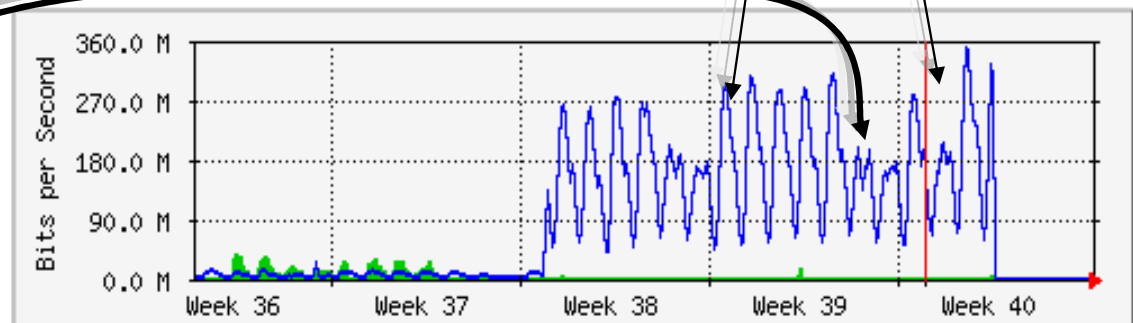

Two cases very different from European model ...

Glo1

What are the generated traffics ? North African consumer case

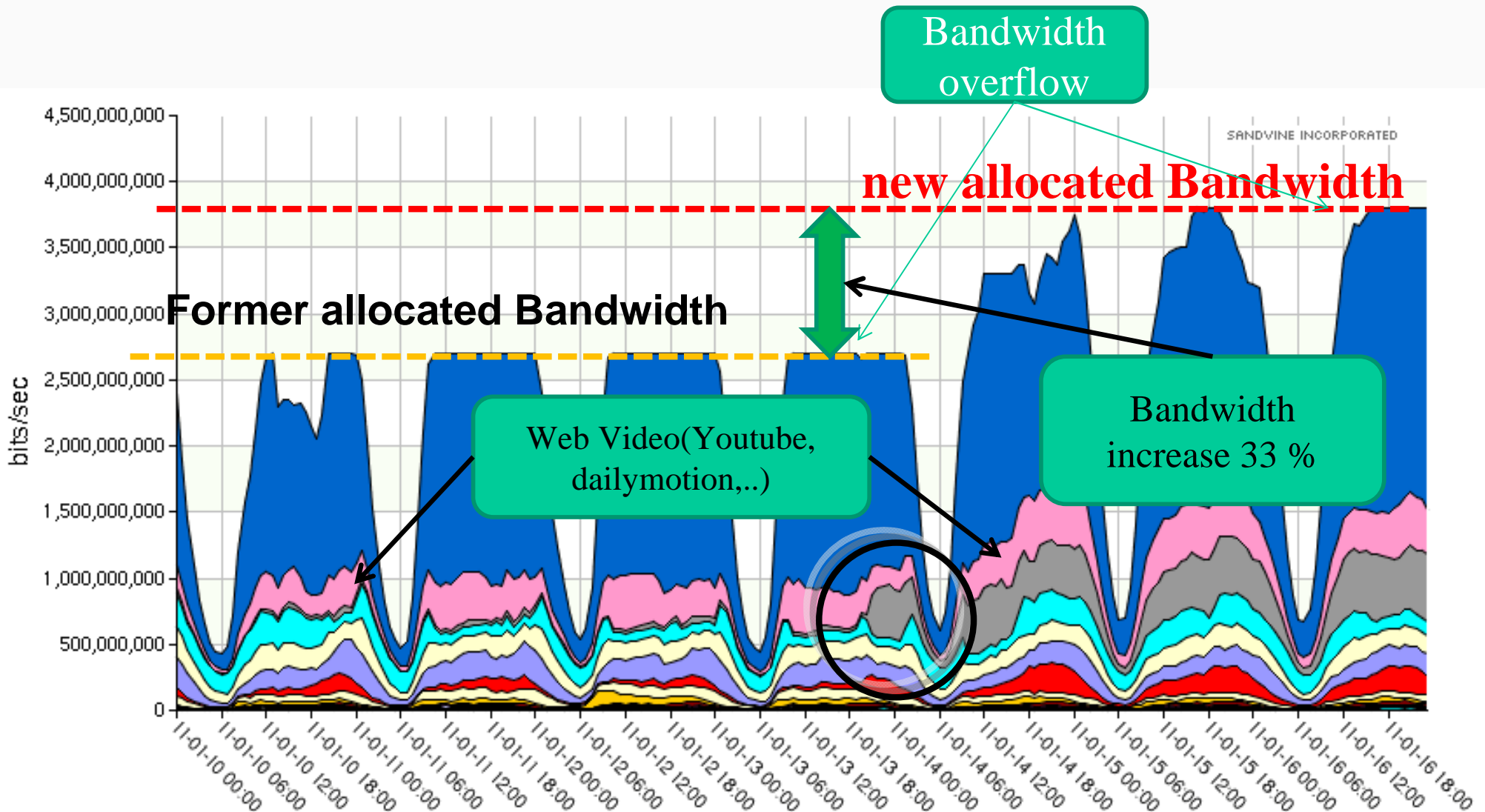

What are the generated traffics ? Kenya 2 week ago

Attack of the
Mole at
Nairobi

'Weekly' Graph (30 Minute Average)

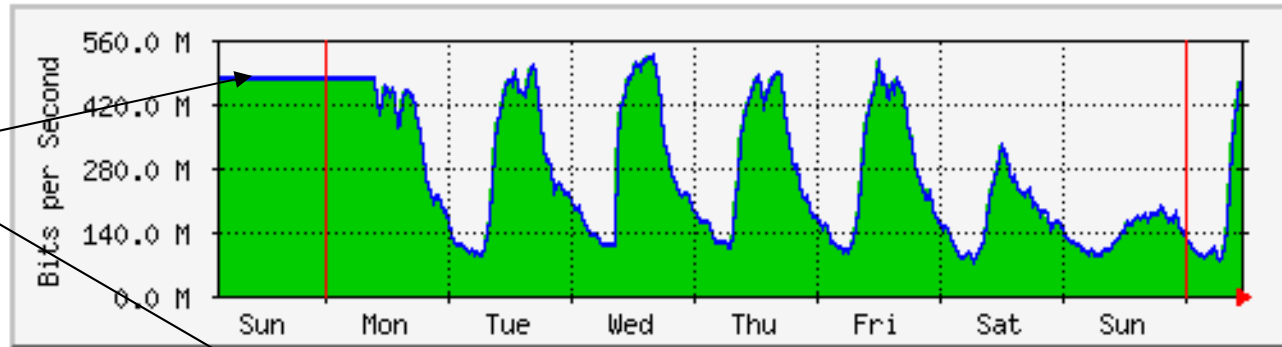

	Max	Average	Current
In	522.3 Mb/s (0.5%)	277.8 Mb/s (0.3%)	452.4 Mb/s (0.5%)
Out	521.7 Mb/s (0.5%)	277.8 Mb/s (0.3%)	448.9 Mb/s (0.4%)

'Monthly' Graph (2 Hour Average)

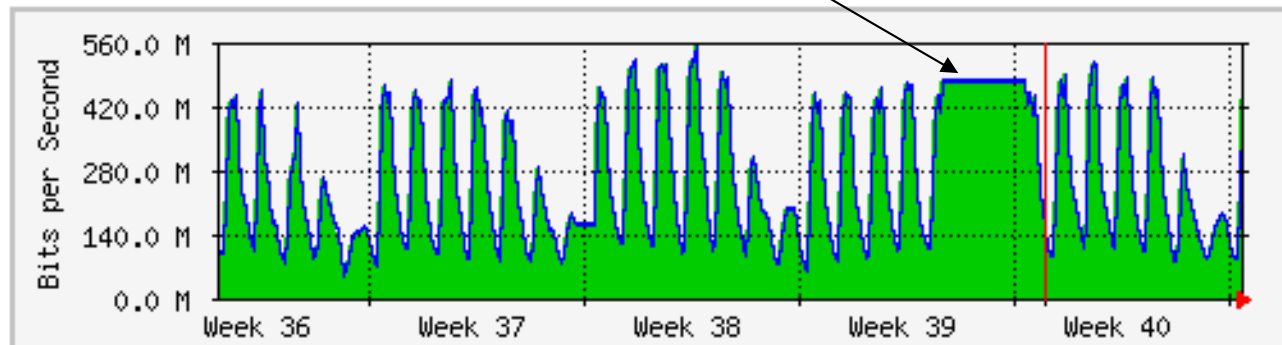

	Max	Average	Current
--	-----	---------	---------

Asymmetry on International bandwidth (Egypt Case)

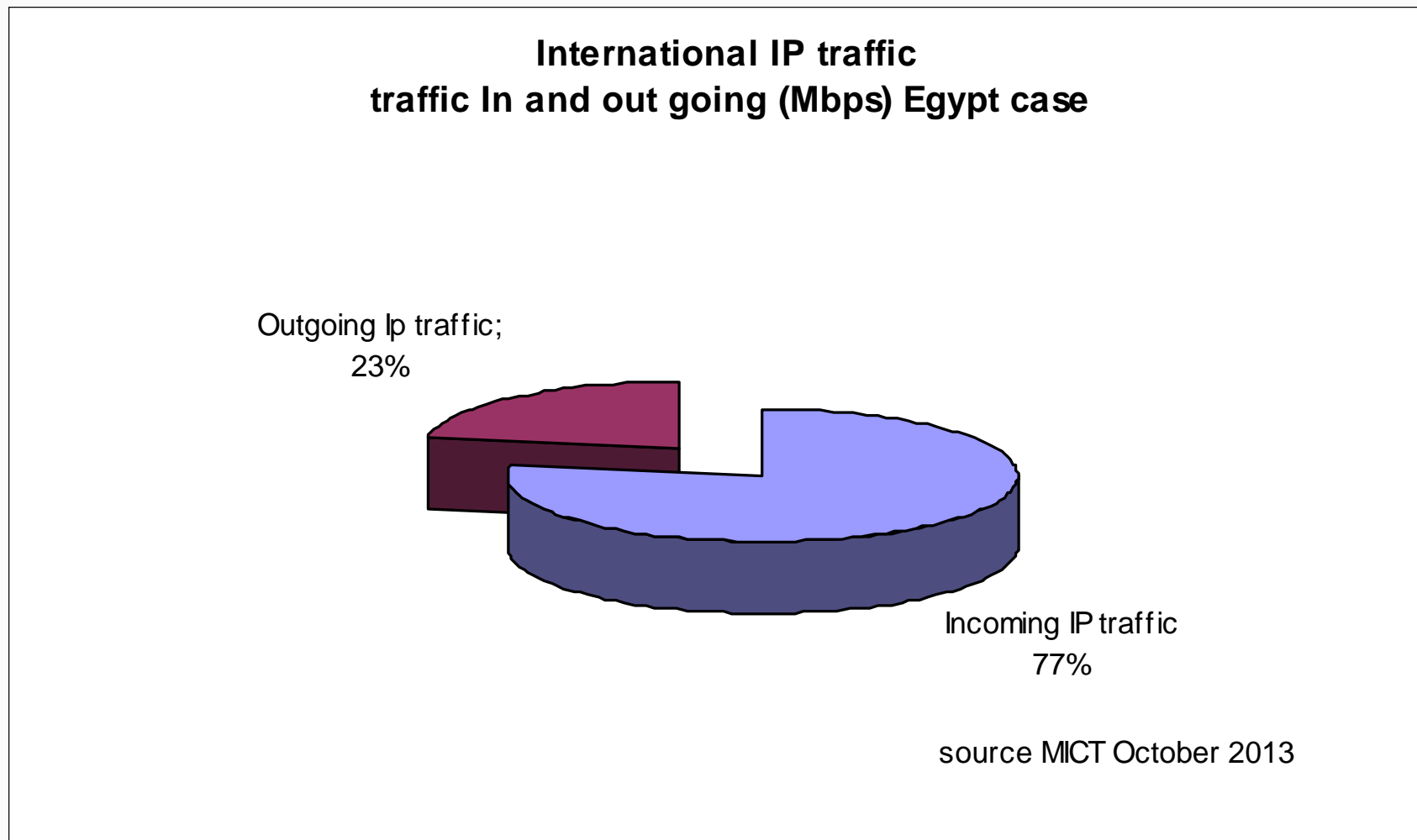

which corresponds to an Asymmetry of demand which have economic impact

How to connect african consumers?

Digital divide North-South

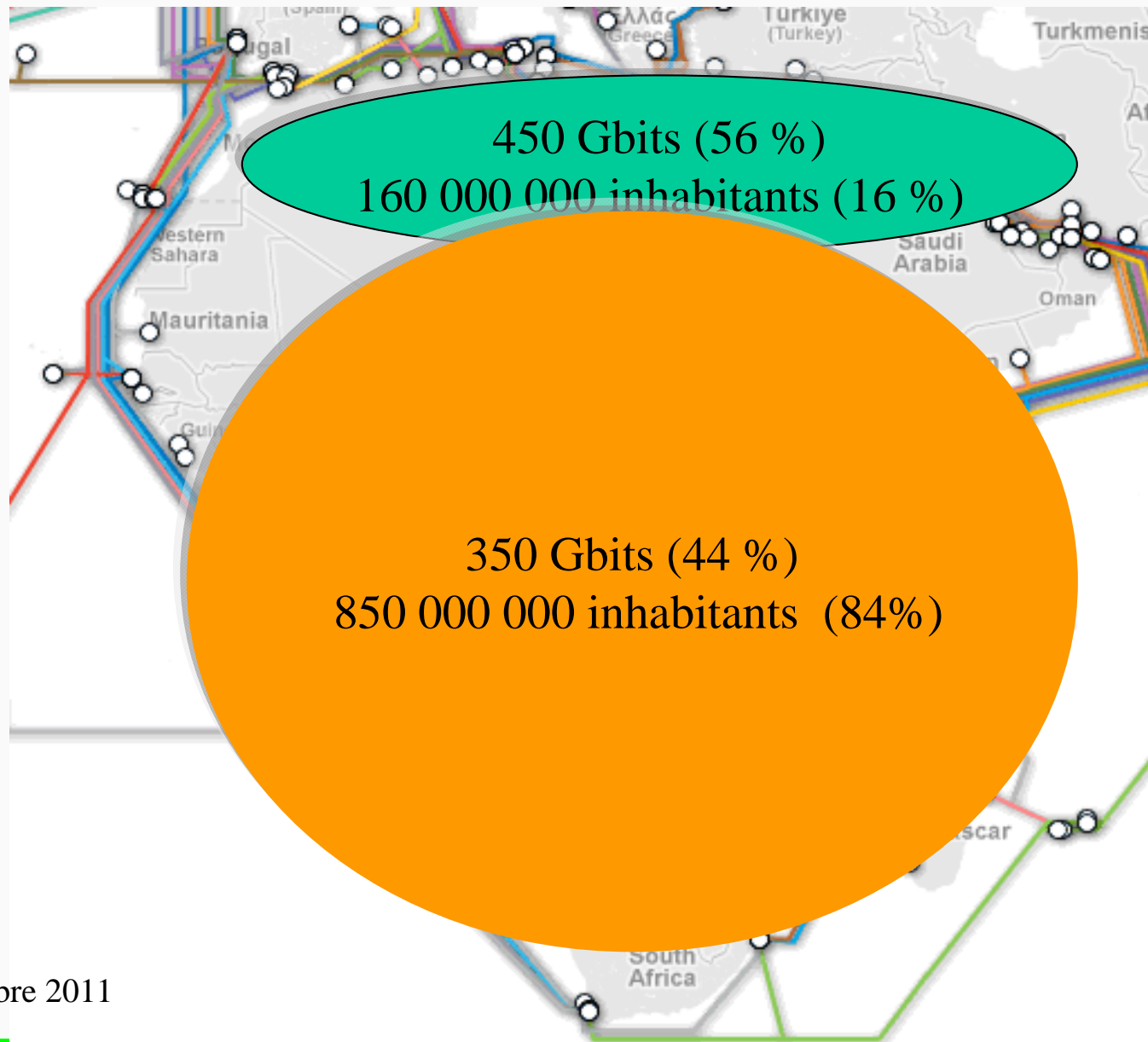

Donnée décembre 2011

Reach the sub marine cable station to have access to International bandwidth

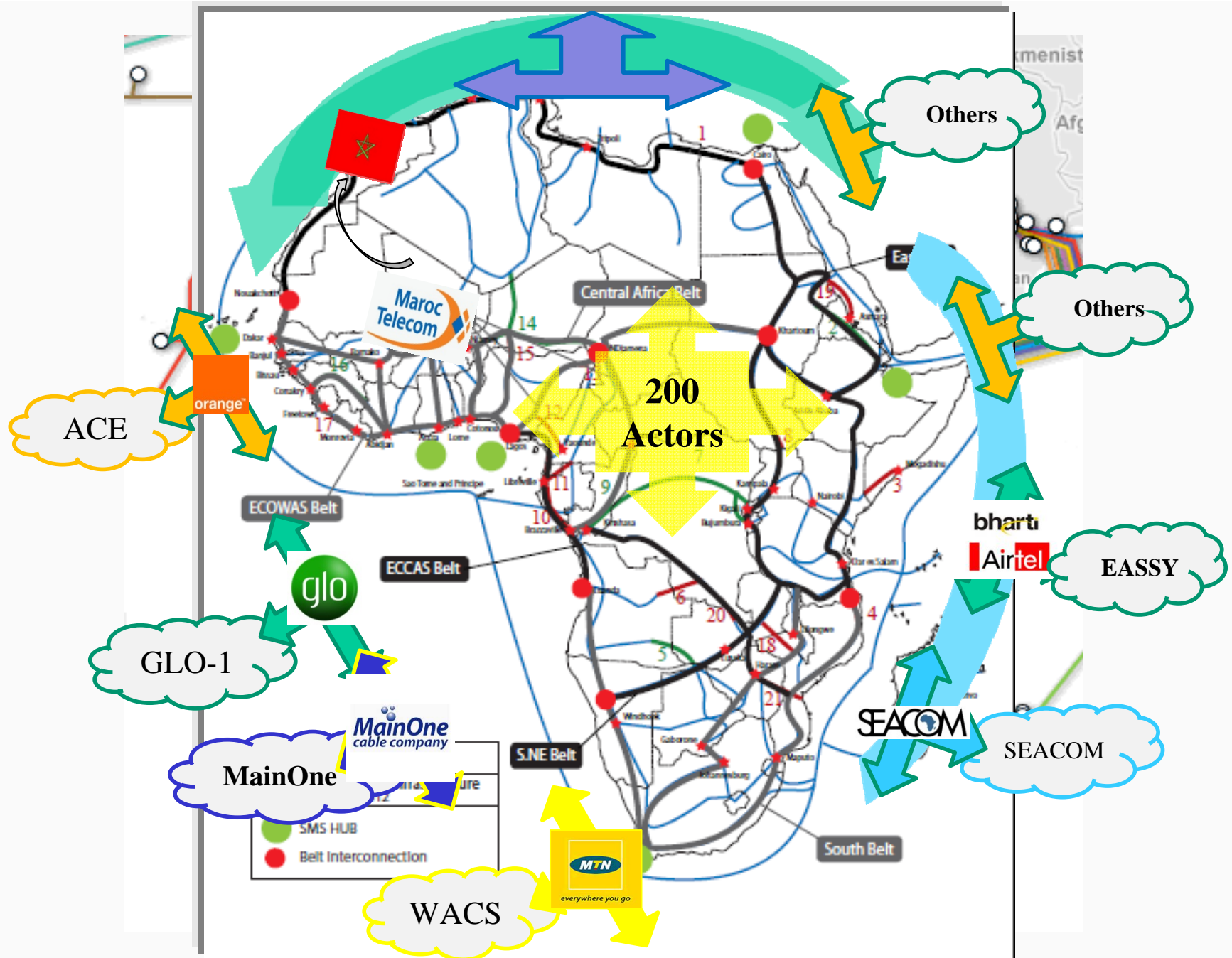

International connectivity :Ghana case

AS37030 Millicom Ghana Limited a.k.a TIGO

Links

[Home](#)
[Report](#)
[Report](#)
[AS](#)
[t](#)
[Routes](#)

[port](#)
[istics](#)
[ss](#)
[nnel](#)
[ation](#)
[is](#)
[v](#)

AS Info

Graph v4

Prefixes v4

Peers v4

Whois

IRR

AS37030 IPv4 Route Propagation

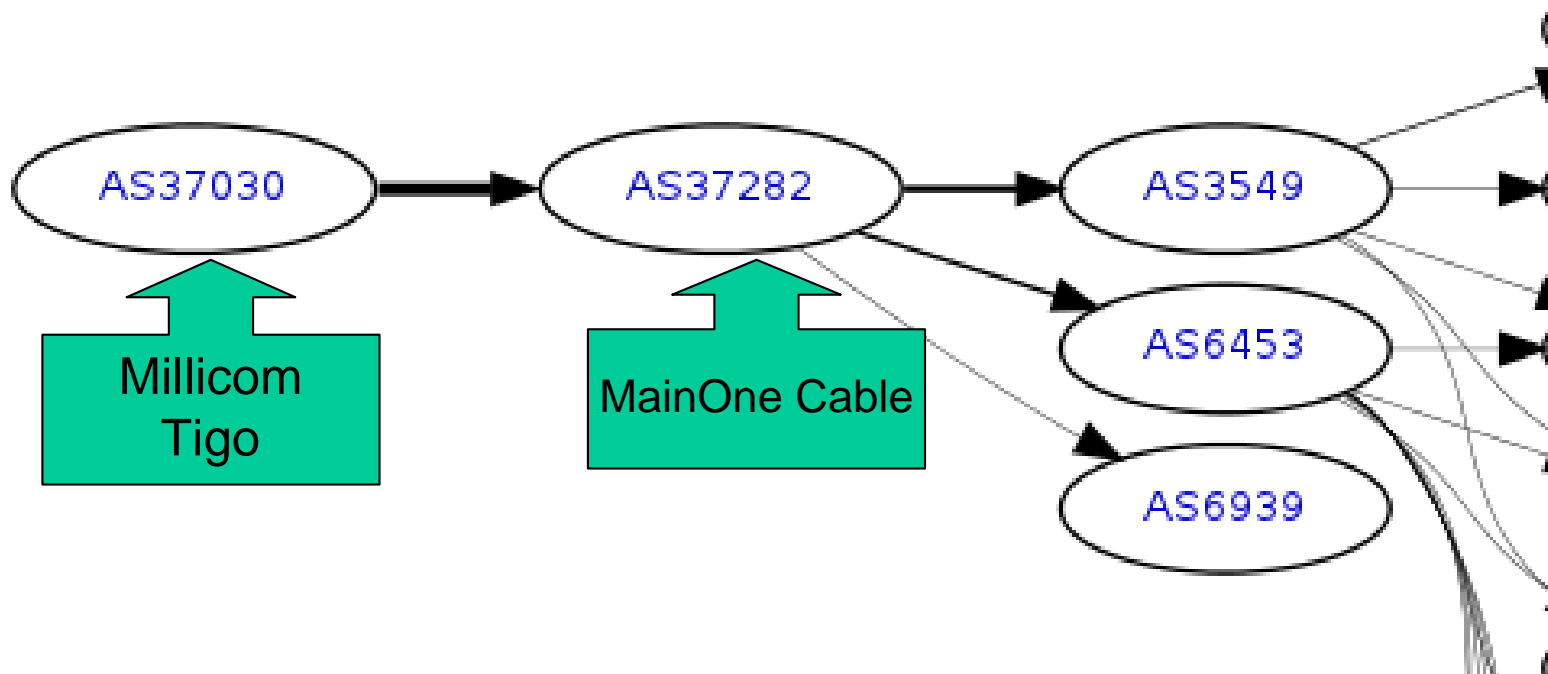

International connectivity : Ghana IXP ecosystem

AS30997 Ghana Internet Exchange AS

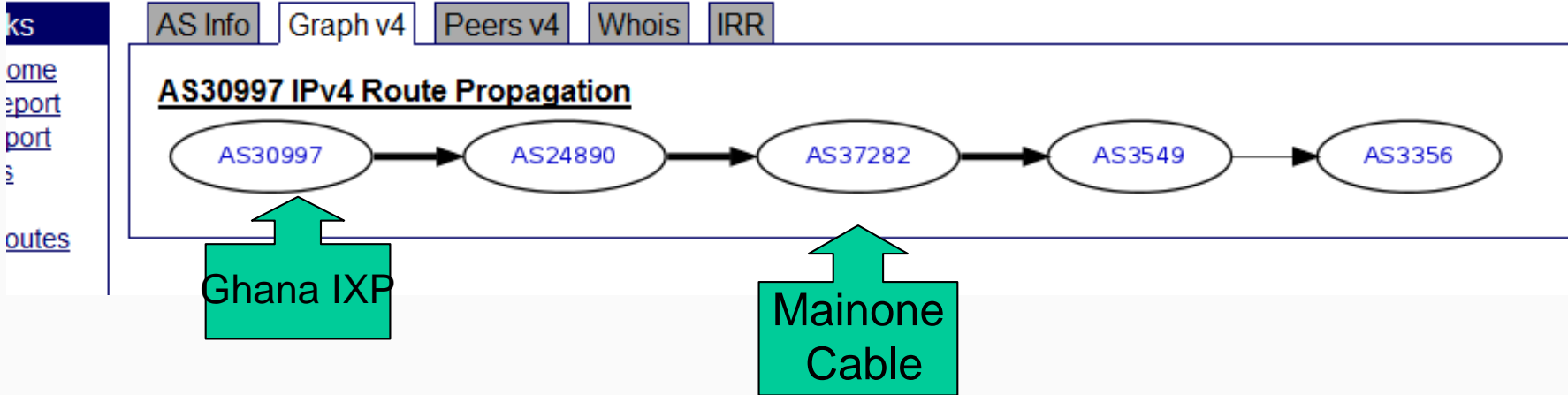

AS30997 IPv4 Peers

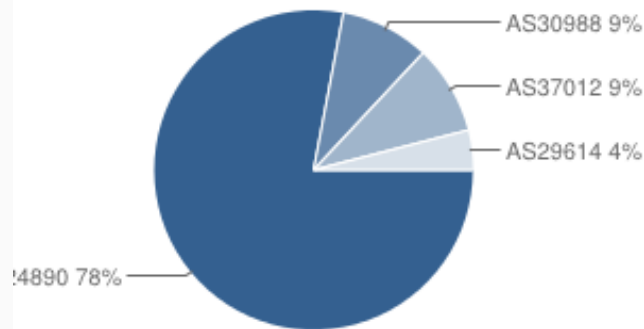

ASN	Name
AS24890	Ecoband Networks Ltd., Ghana
AS30988	IS InternetSolutions Limited
AS37012	Comsys Ghana Ltd
AS29614	GHANA TELECOM ISP NETWORK

Ghana have 37 ASN
4 are peering

International connectivity :Tunisia IXP-ATI

AS2609 Tunisia BackBone AS

- links
- Home
- Report
- Report
- es
- t
- Routes
- port
- istics
- ss
- nnel
- ation
- is
- :

AS Info | Graph v4 | Graph v6 | Prefixes v4 | Prefixes v6

AS2609 IPv4 Route Propagation

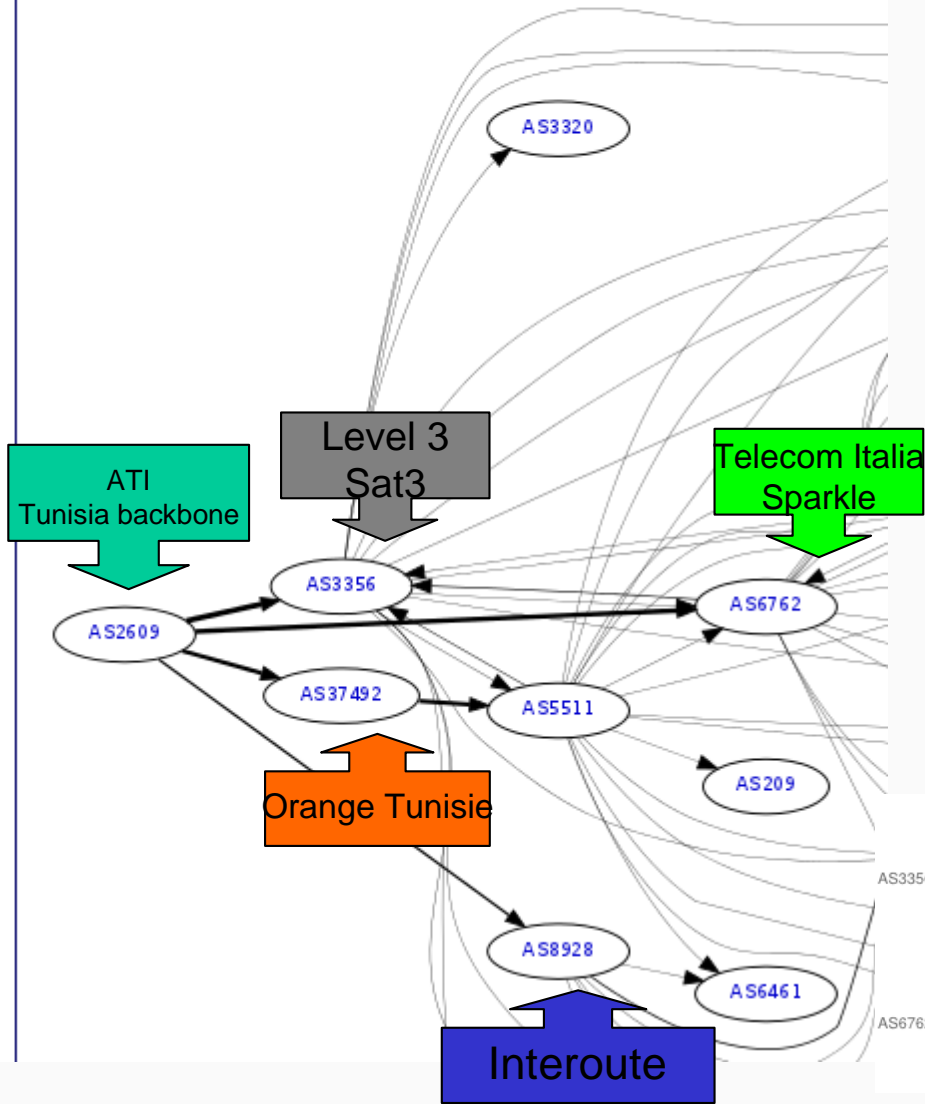

Peering

AS2609 IPv4 Peers

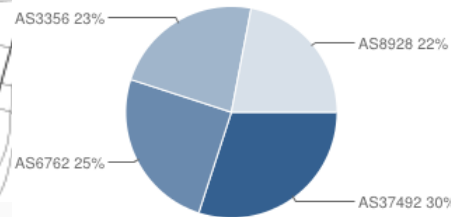

ASN	Name
AS37492	Orange Tunisie
AS6762	TELECOM ITALIA SPARKLE S.p.A.
AS3356	Level 3 Communications, Inc.
AS8928	Interoute Communications Limited

International connectivity :Tunisia IXP-ATI (2)

The Internet Exchange platform

Last Day

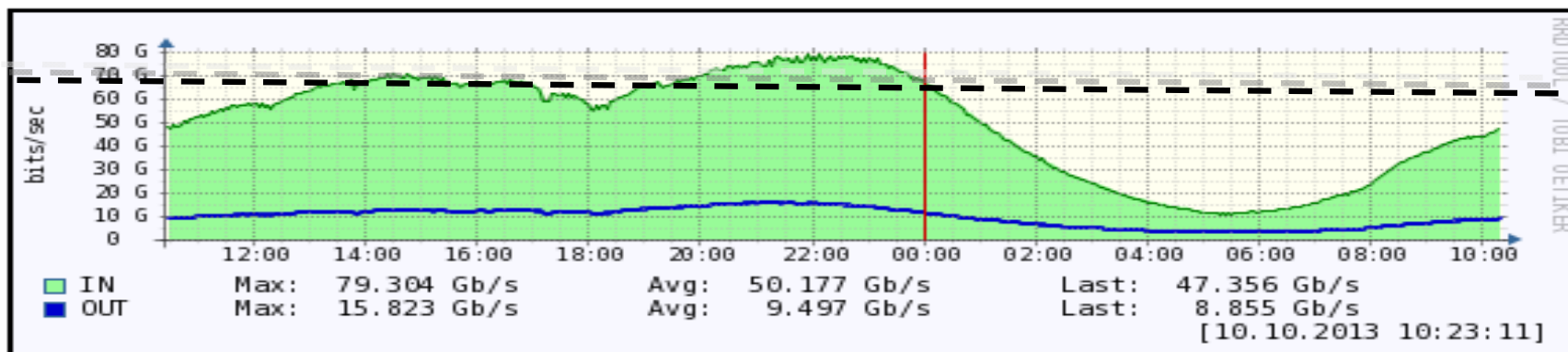

Last Week

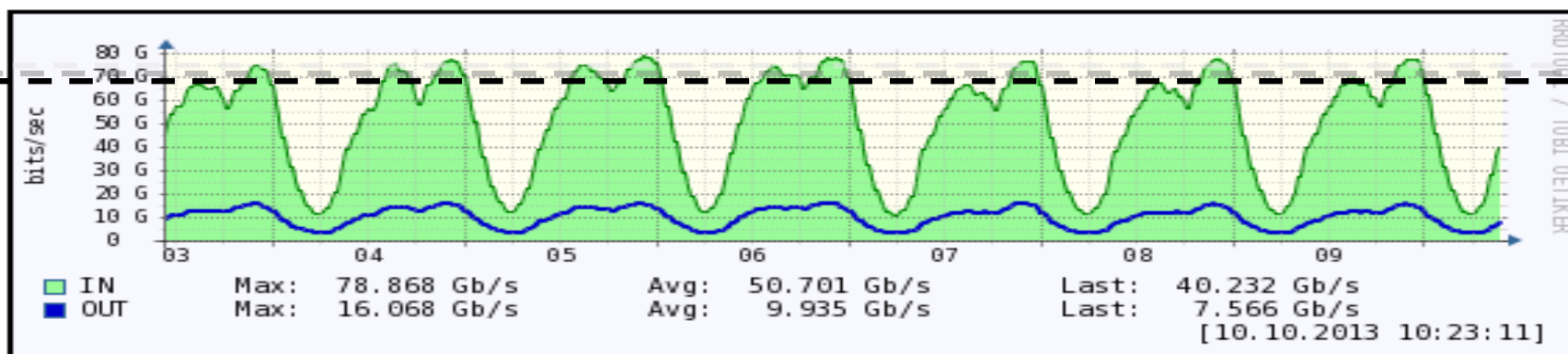

Reduce international bandwidth usage -IXP Africa October 2013

- ▶ The usage of international bandwidth has an important impact on the end user price...
 - ▶ How to reduce this point?
- ▶ Intra country traffic shall stay in the country
 - ▶ IXP
 - ▶ Peering
- ▶ Intra regional traffics shall transit via terrestrial infrastructure as possible
 - ▶ Regional infrastructure
 - ▶ Regional peering
- ▶ Implement Cache
 - ▶ At IXP node
 - ▶ Per operator/ISP

Return of the field < 20-25%



Bandwidth price vs Bandwidth : Financial approach

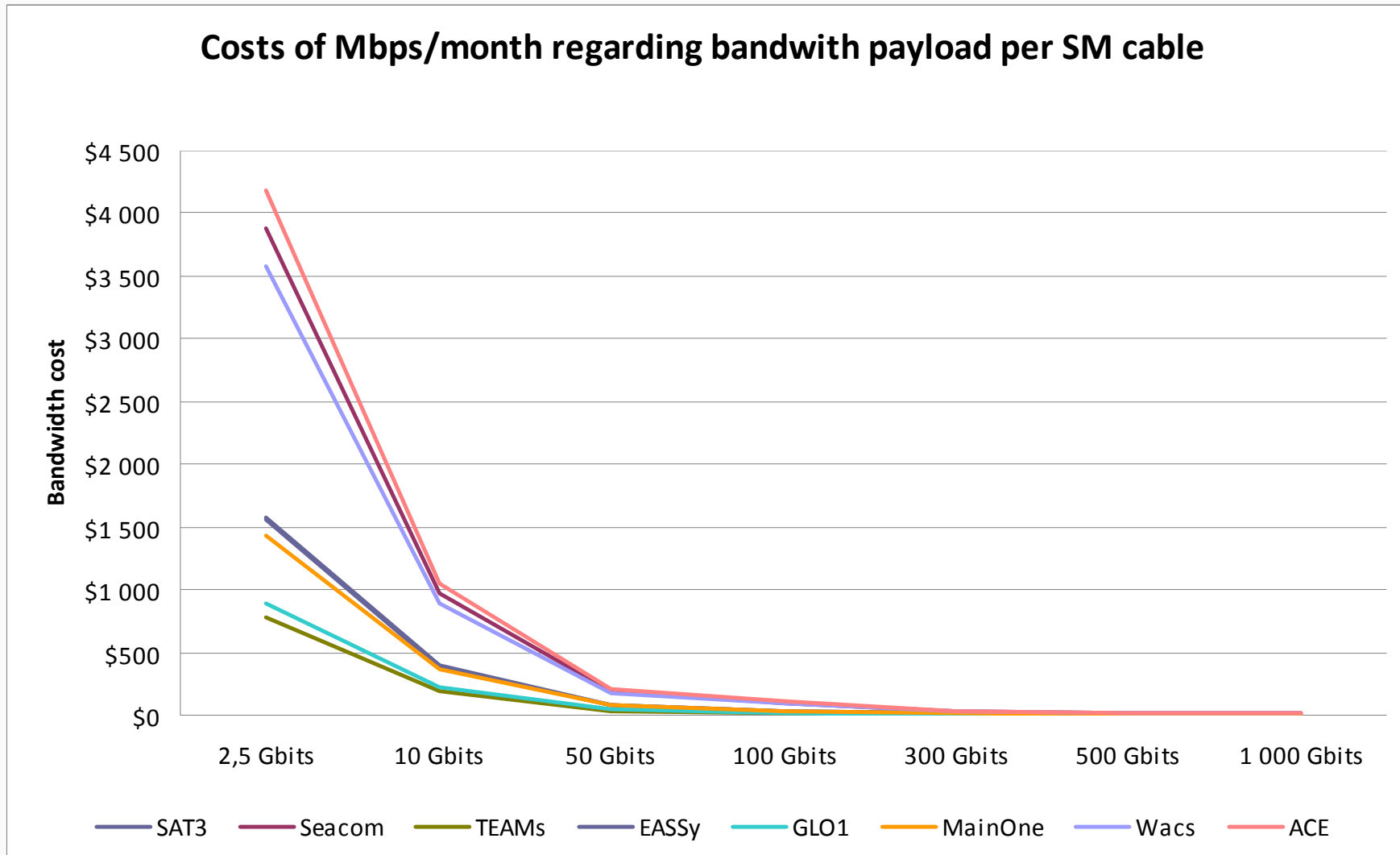

Broadband access: Tunisia case

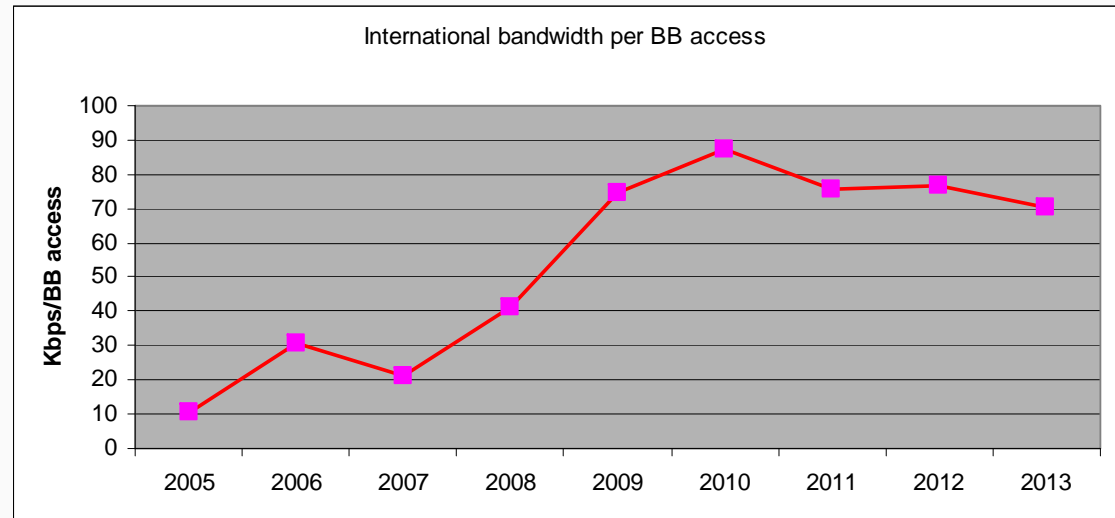
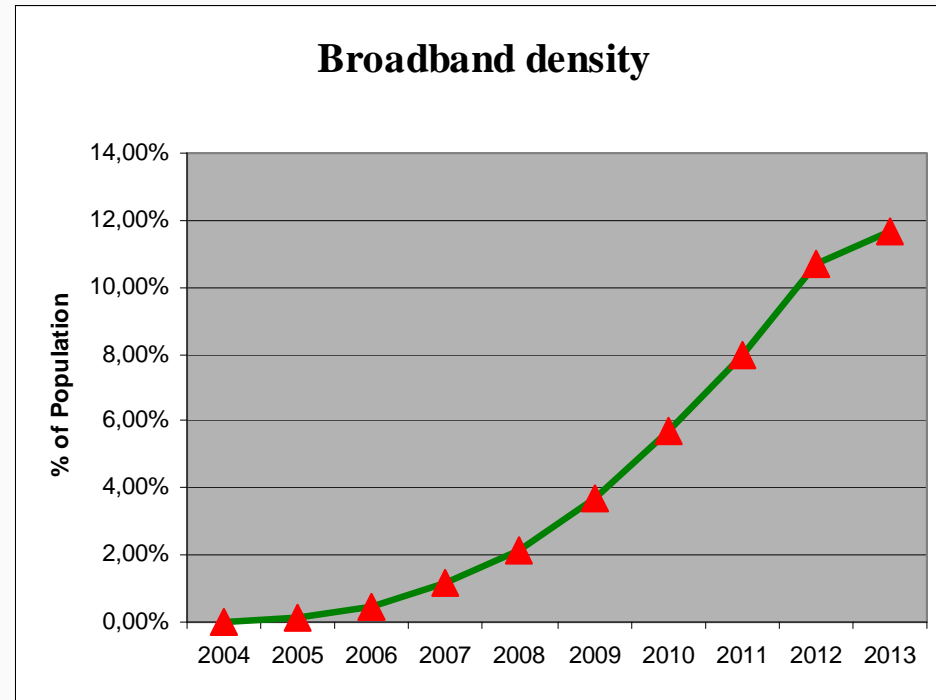
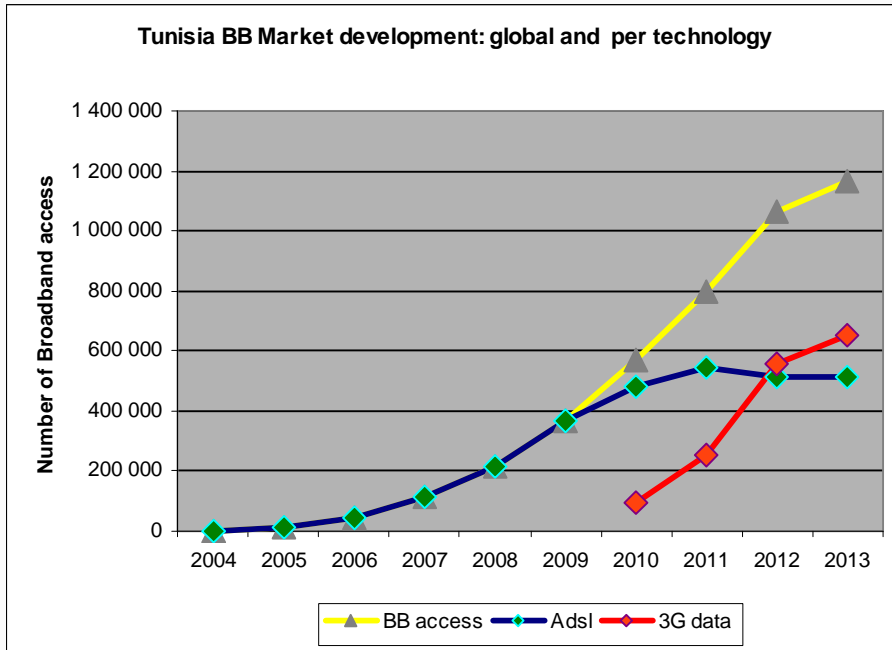

Broadband access: Tunisia case

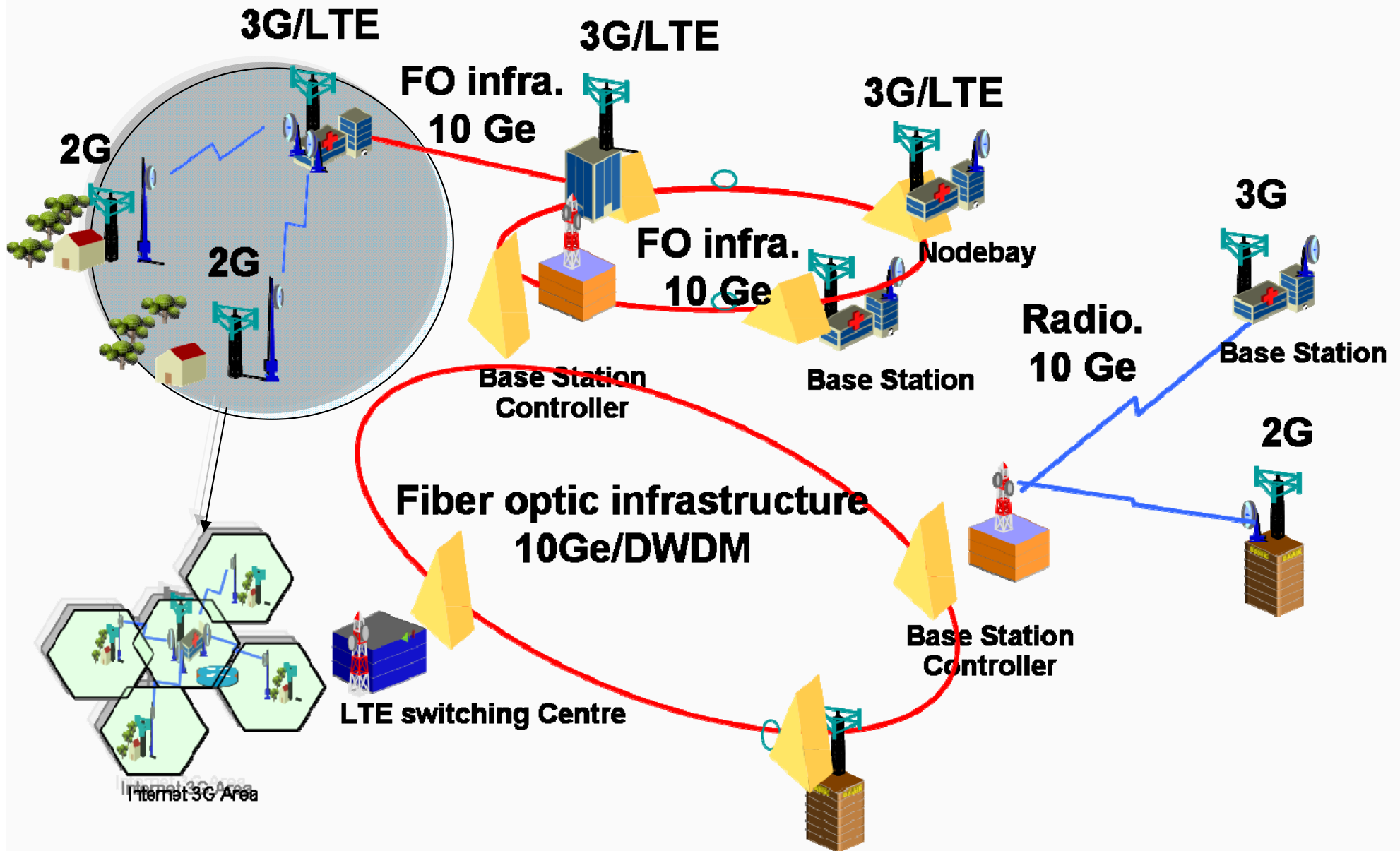

Impact of backbone/Backhaul investment on Bandwidth cost

Finance data information

Taux (%) (WACO 20%,80%)	Duration of the loan (Number of Years)	ROI (For yearly rental)
7,00%	2	10

Maintenance rate

Taux (%)	
4,00%	

Infrastructure cost

Cable optique		
Cable	Length in KM	Cost per KM (\$)
Cable+pose	100	\$20 000

Financial analysis

Cout total du Projet (CAPEX)	\$2 661 262	
	annual	Monthly
Reimbursement (Capex)	\$266 126	\$22 177
Maintenance (opex)	\$106 450	\$8 871
Global cots (opex+Capex)	\$372 577	\$31 048

Cost of IP Mbps/Monthly vs traffic

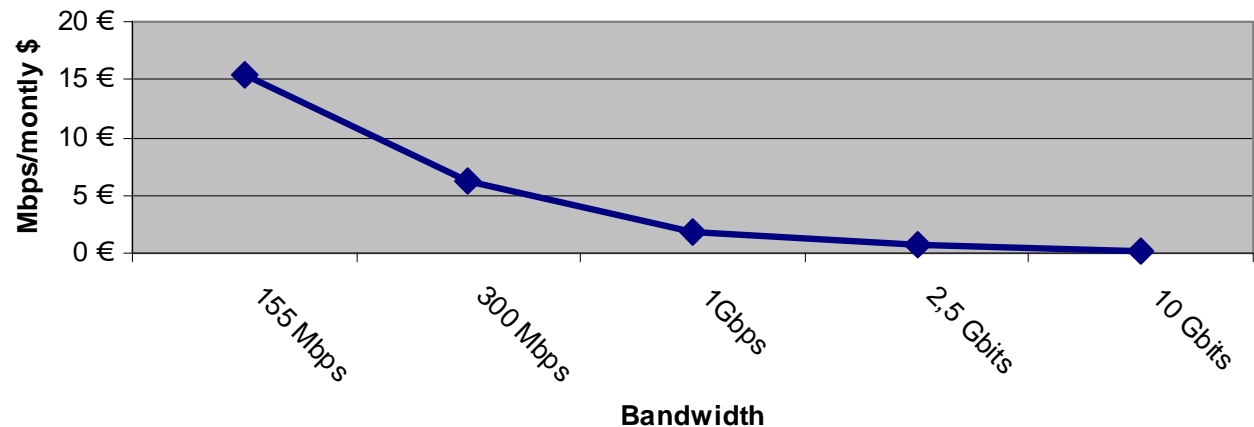

BB density vs bandwidth per BB access...an indicator of quality ?

Indicator of BB quality in some African Countries

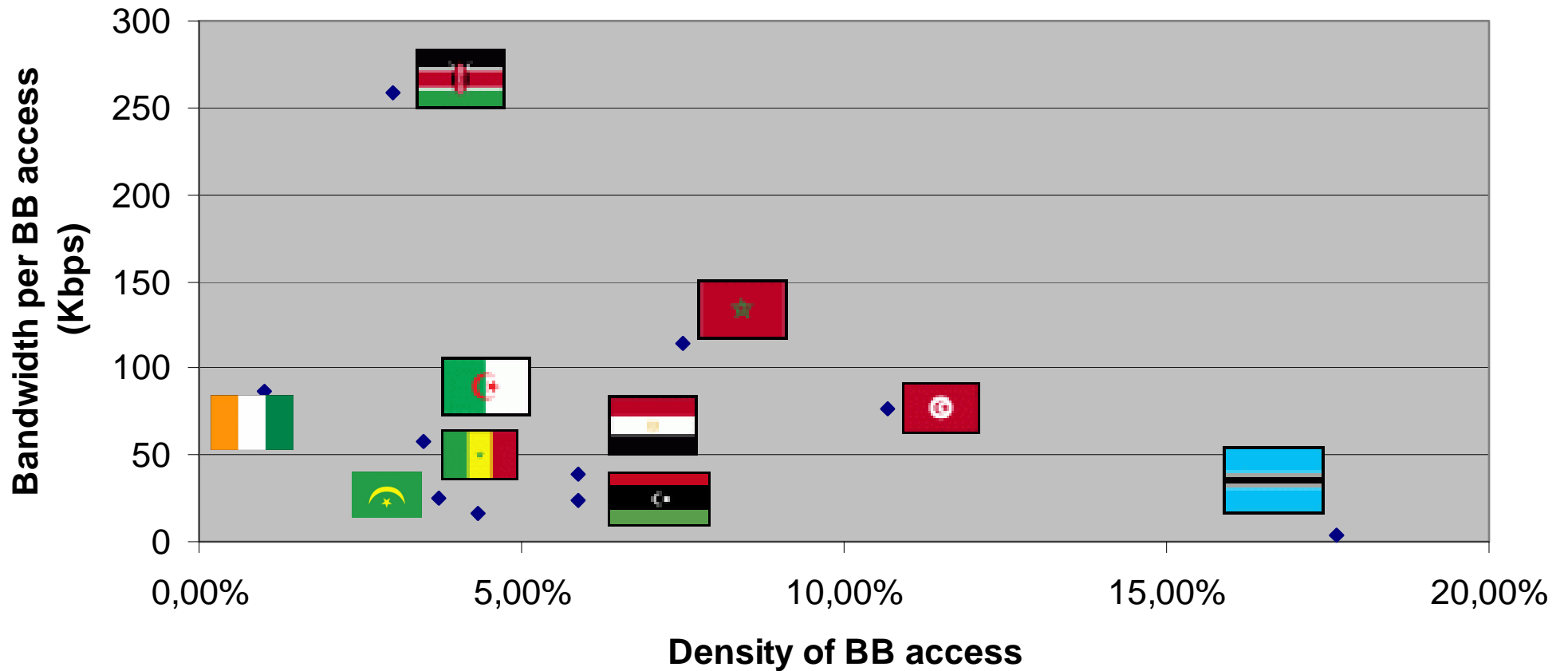

Infrastructure Driving Factors of Network Congestion in Africa

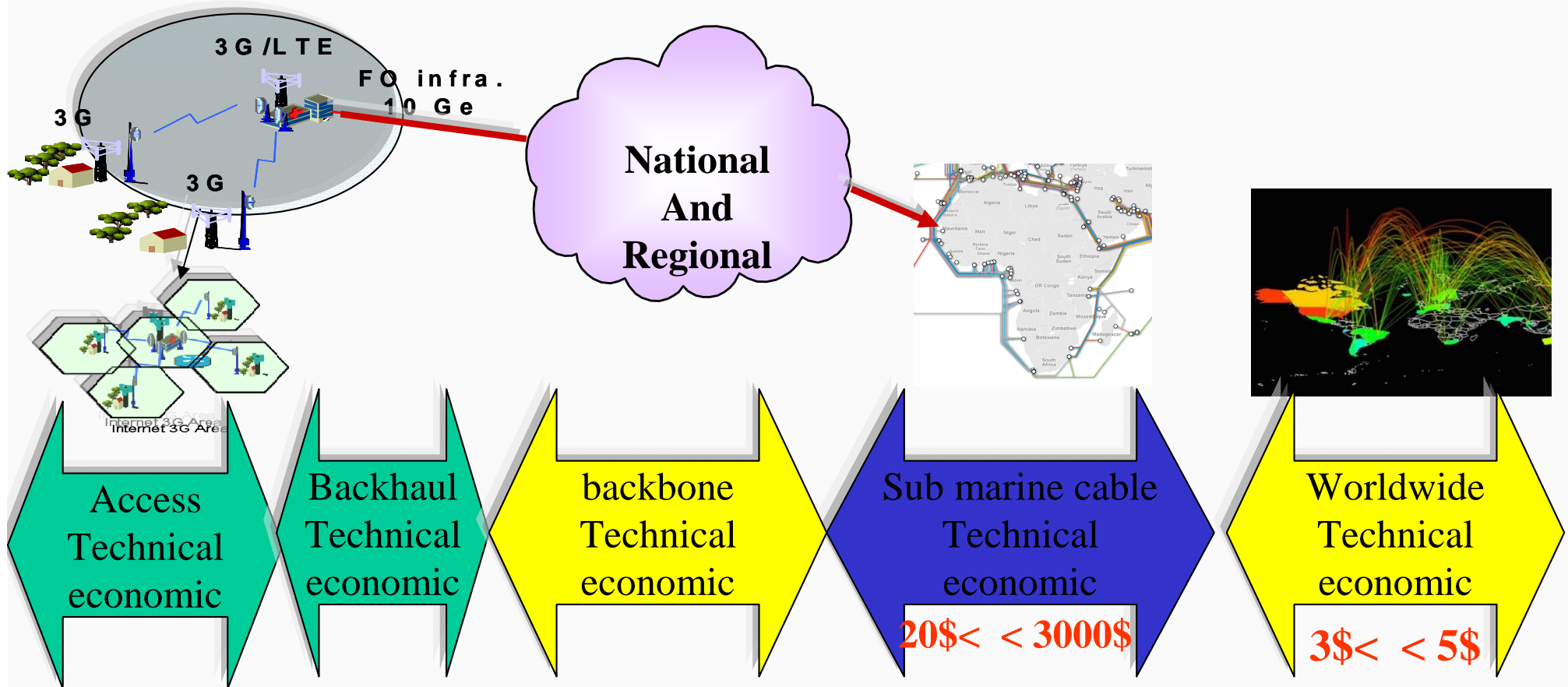

Radio vs Terrestrial
infrastructure
Licence cost
Spectrum cost

National and
regional backbone

Value Chain of internet in Africa

**because 3G-LTE Fixe data become reference technology
to support BB services**

Developing effective and sustainable policies

A large number of exogenous factors are impacting on QoS and pricing of Internet, Infrastructure access is one of the major in Africa

Solutions?

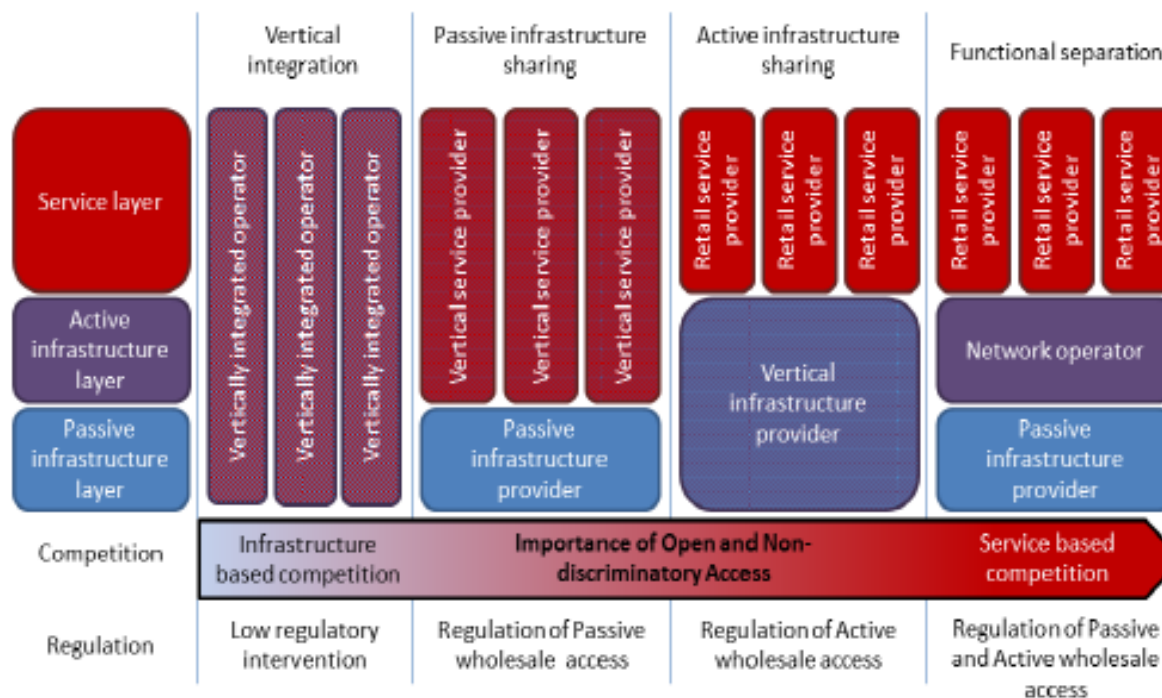

Source: forthcoming Natalija Gelvanovska, Michel Rogy, Carlo Maria Rossotto, "Broadband Networks in MENA: Accelerating High-Speed Internet Access", World Bank Report No: ACS4718

Quality of internet in Africa

Broadband access MAU + Egypt (Global et per technology)

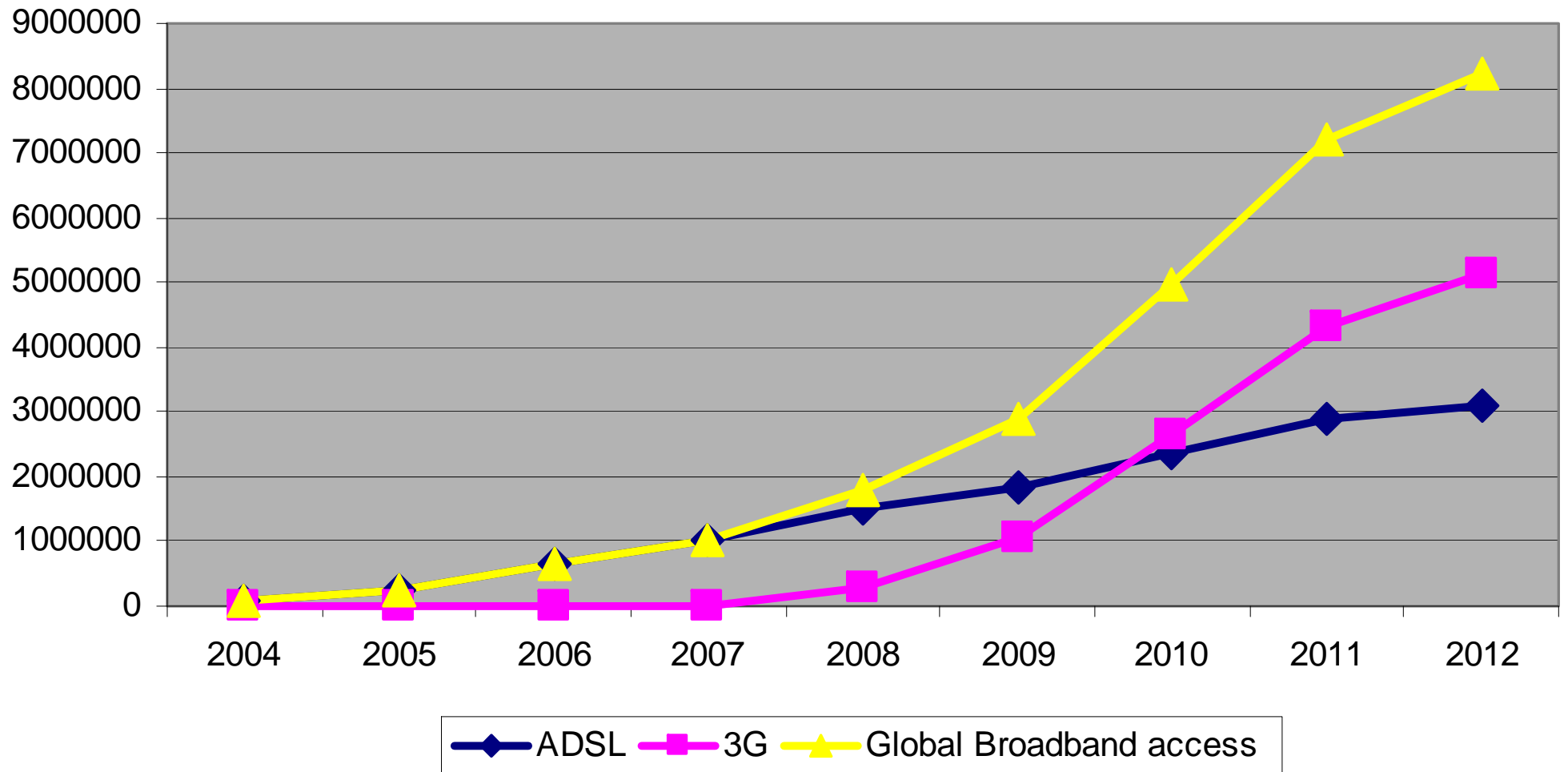

Quality of internet in Africa

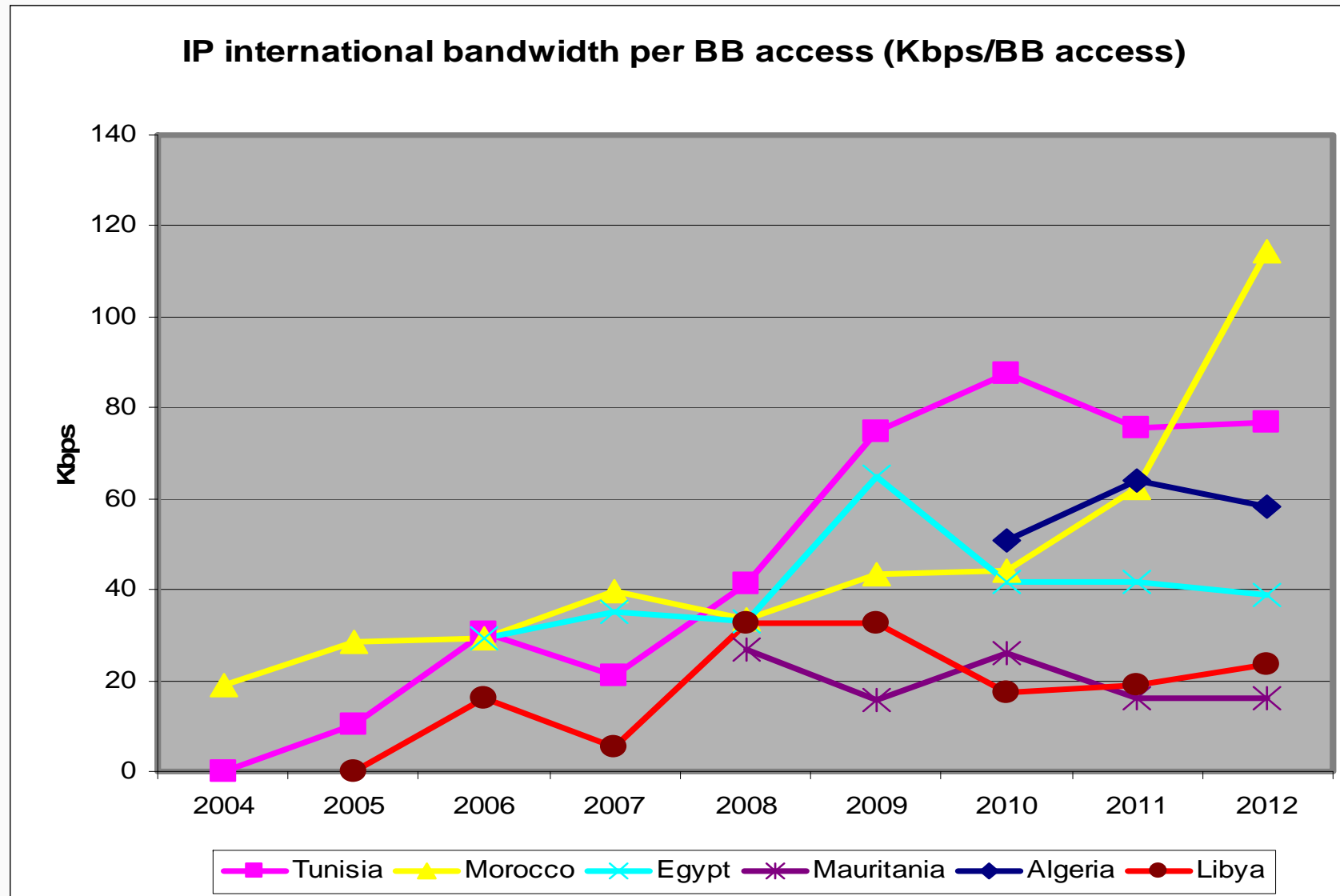

Africa IP traffic: Historical and projection

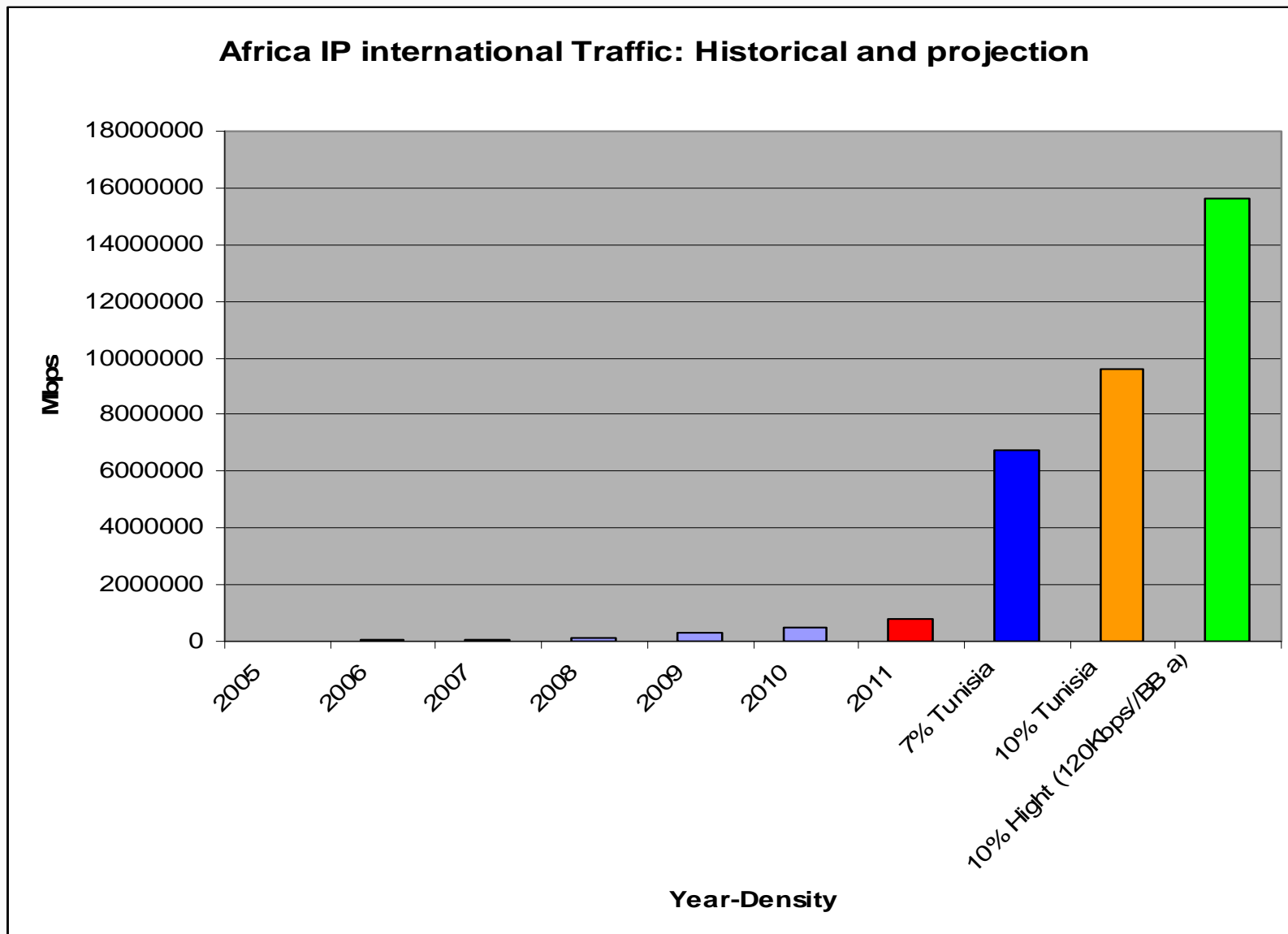

Smart pricing Value Chain African case (4) (Tunisia Case)

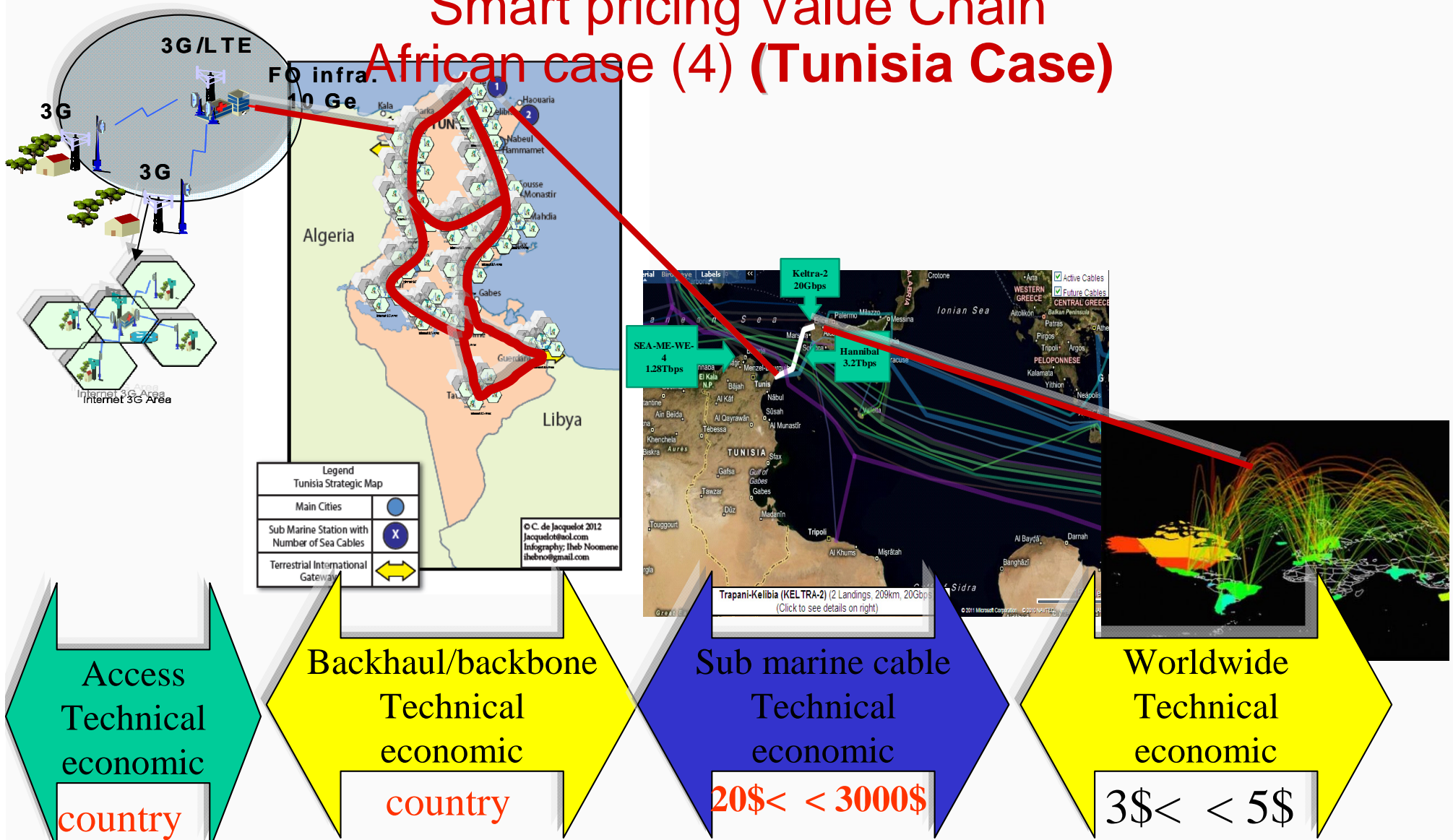

Value Chain of internet in Africa

because **3G-LTE** Fixe data become reference technology
to support **BB services**

MERCI

OBRIGADO

THANK YOU

Muchas gracias

Grazie mille

شكرا

Round table

Driving Factors of Network Congestion and economic aspects African case (1)

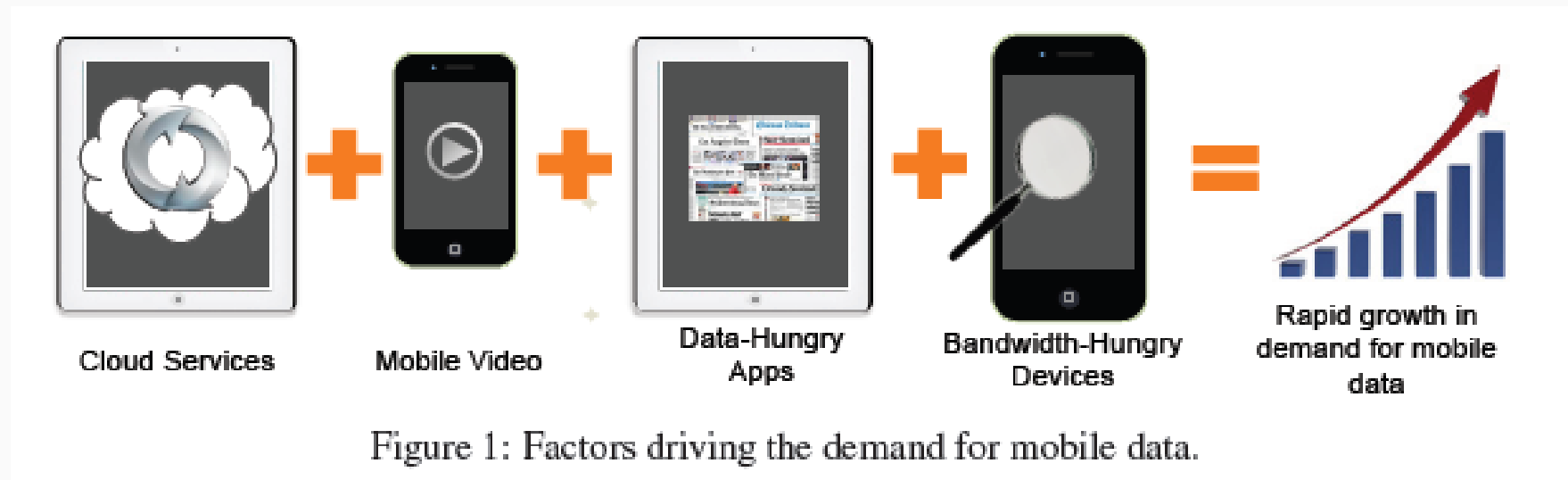

- ▶ During 2000-201x Years, the transposition of Mobile vs Fixe by the African consumers is a fact
- ▶ The emergency of broadband in Africa will be (is) based on the usage's transposition of Internet 3G (4G) data vs fixe technologies (Adsl, Coax,...)...
- ▶ For exemple 3G IP data traffic of Tunisia is equivalent of 50 % of France one

Driving Factors of Network Congestion African case (3) Mauritania Case study

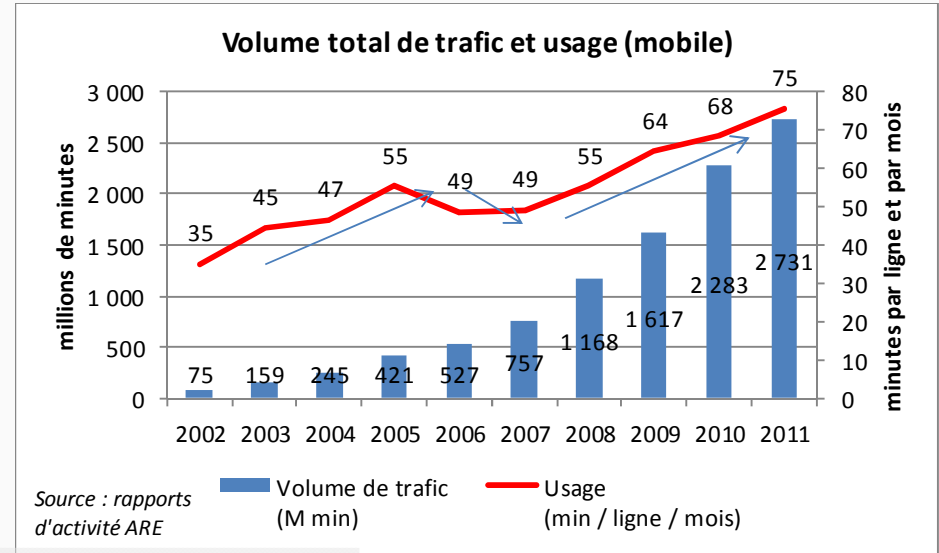
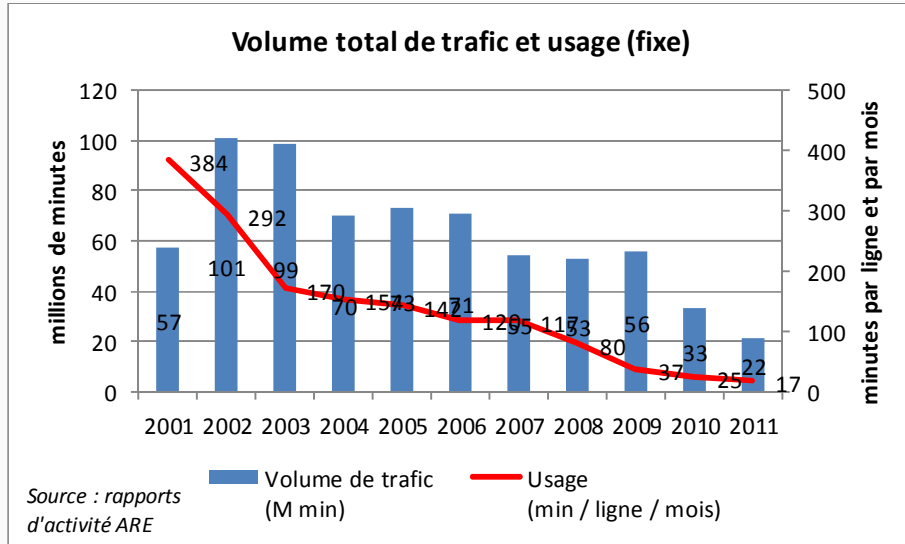

Internet 3G data Impact

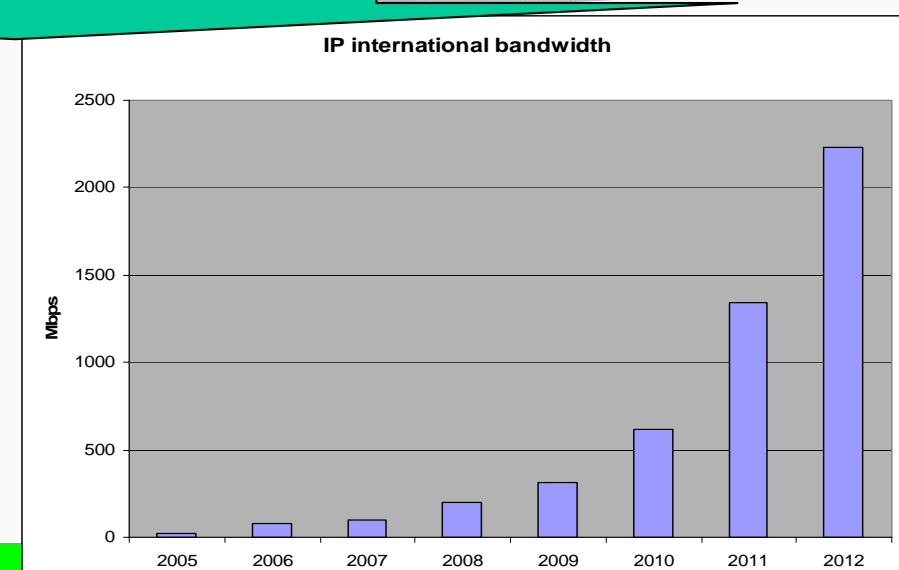
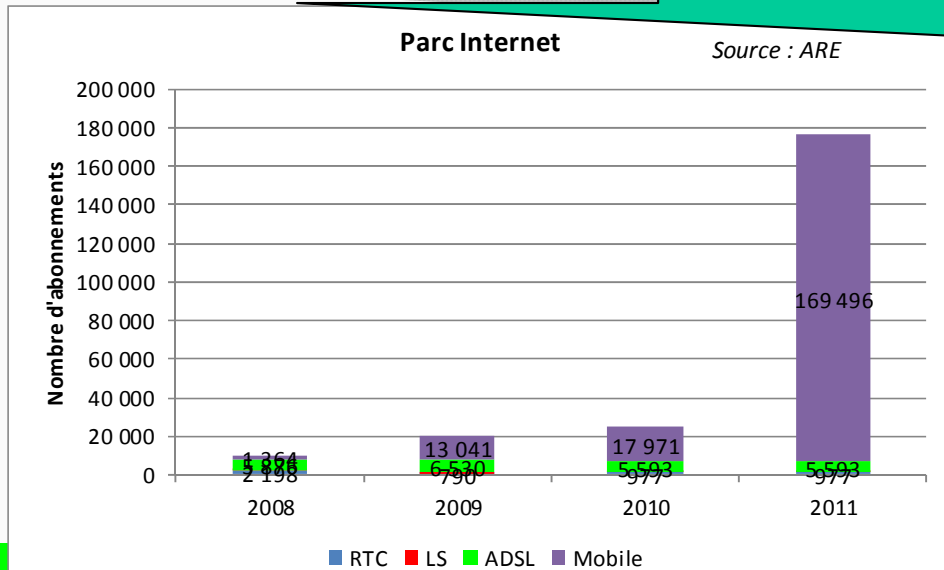

Driving Factors of Network Congestion

African case (3)

Quality of internet in Africa

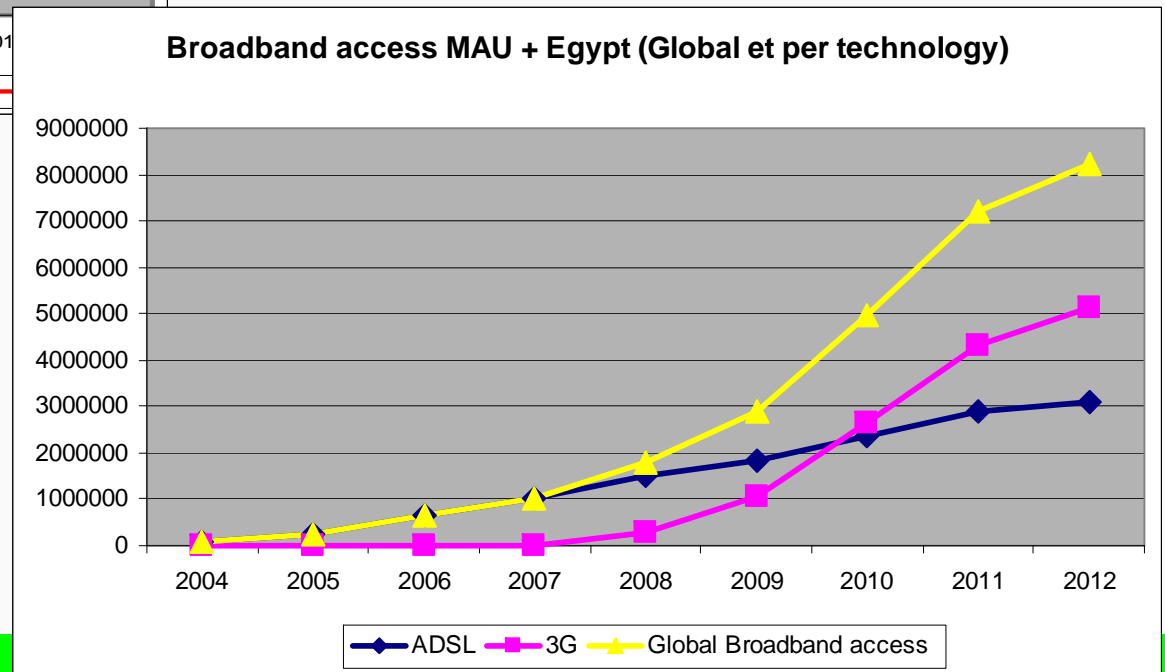
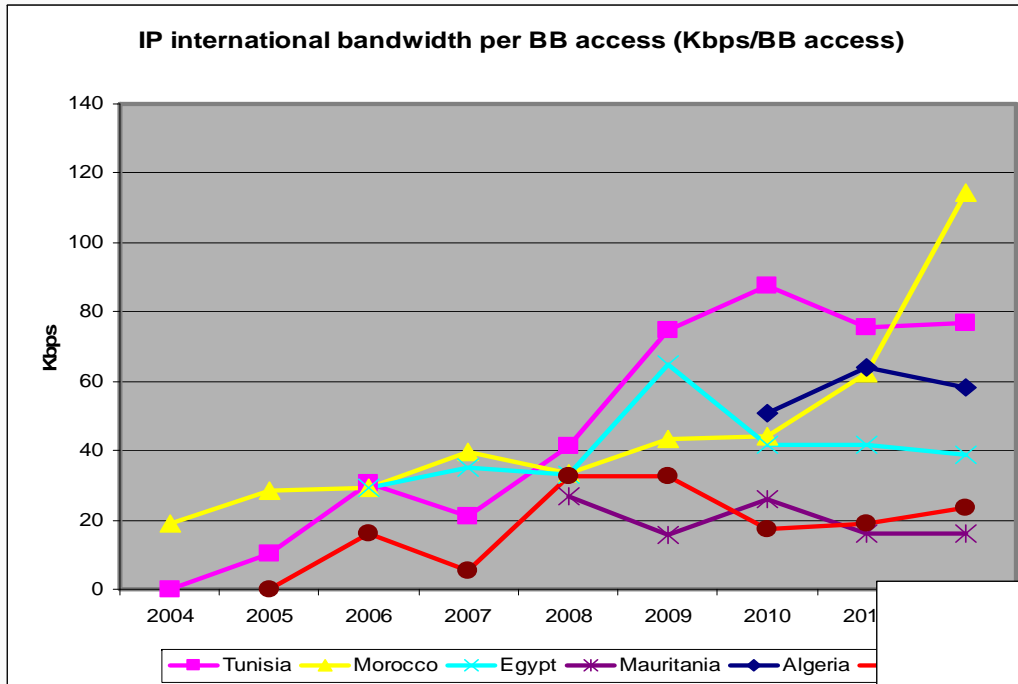

Driving Factors of Network Congestion African case (4) (Tunisia Case)

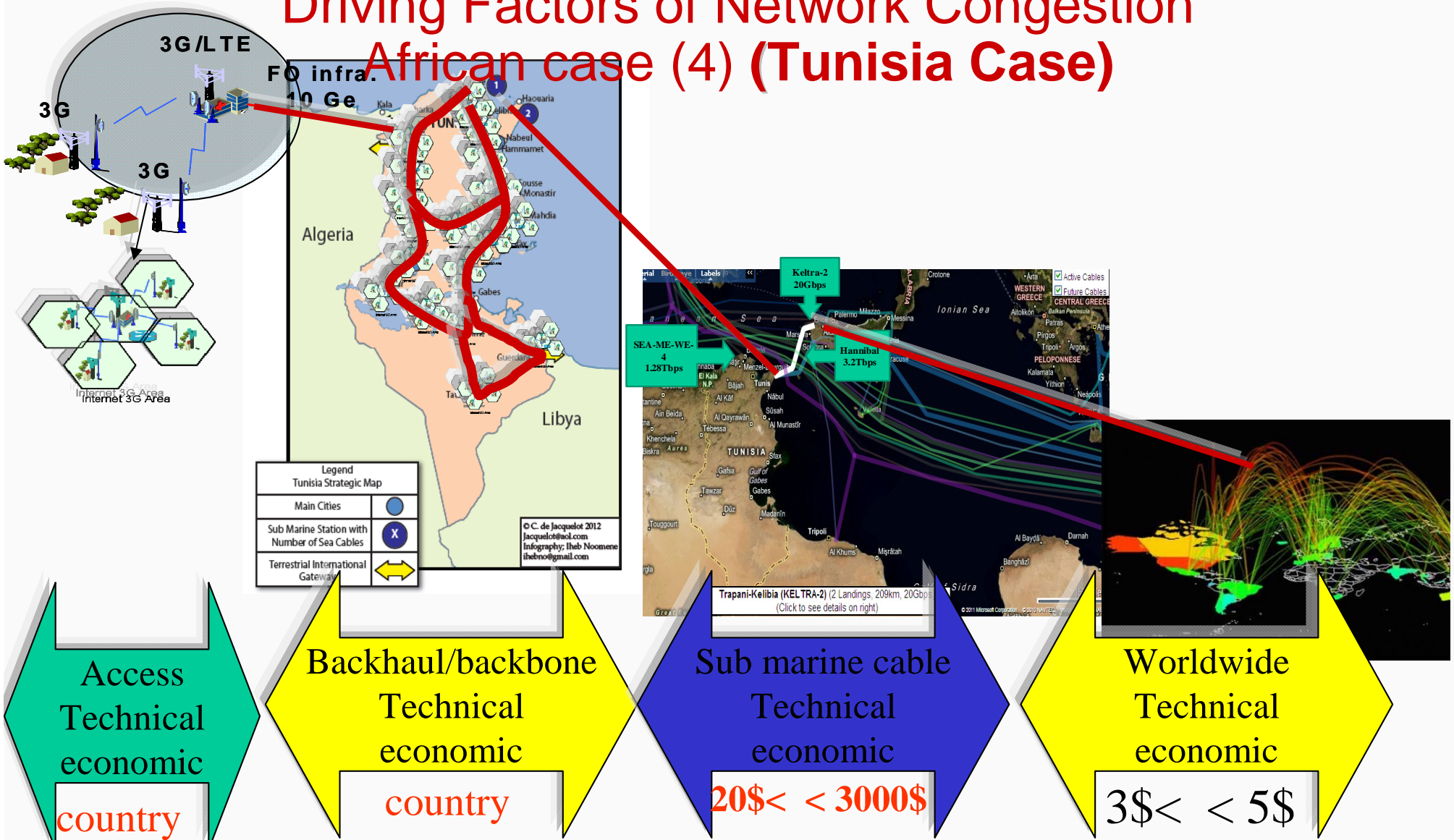

Value Chain of internet in Africa

because 3G-LTE Fixe data become reference technology
to support BB services